

# BET-102 Basic Electronics Engineering.

## Chapter-1

### 1. ELECTRONIC DEVICES

#### 1.1 Define Electronics & its application.

The world's reliance on electronics is so great that commentators claim people live in an "electronic age." People are surrounded by electronics—televisions, radios, computers, mobiles, Laptop and DVD players, along with products with major electric components, such as microwave ovens, refrigerators, and other kitchen appliances, automatic vehicles, Robotics, as well as hearing aids and medical instruments and numerous applications in industry.

**Definition:** The branch of engineering which deals with current conduction through a Vacuum or Gas or Semiconductor is known as **Electronics**. An *electronic device* is that in which current flows through a vacuum or gas or semiconductor. This control of electrons is accomplished by devices that resist, carry, select, steer, switch, store, manipulate, and exploit the electron.

Or

Electronics deals with electrical circuits that involve active electrical components such as vacuum tubes, transistors, diodes and integrated circuits, and associated passive interconnection technologies. Commonly, electronic devices contain circuitry consisting primarily or exclusively of active semiconductors supplemented with passive elements; such a circuit is described as an electronic circuit.

#### **Pre Knowledge (Some of the basic definitions):**

**Passive Components:** Capable of operating without an external power source. Typical passive components are **resistors, capacitors, inductors**.

**Active components:** Requiring a source of power to operate. Includes transistors (all types), integrated circuits (all types), TRIACs, SCRs, LEDs, etc.

#### **APPLICATIONS of Electronics:**

*Electronic components:* capacitor (C), cathode ray tube (CTR), diode (D), digital signal processor (DSP), field effect transistor (FET), integrated circuit (IC), junction gate field effect transistor (JFET), inductor (L), Liquid crystal display (LCD), light dependent resistor (LDR), light emitting diode (LED), Metal oxide semiconductor field effect transistor (MOSFET), transistor (Q), resistor (R), relay (RLA, RY), switch (SW), transformer (T), thermistor (TH), transistor (Tr), integrated circuit (U, IC), variable capacitor (VC), variable resistor (VR) and more.

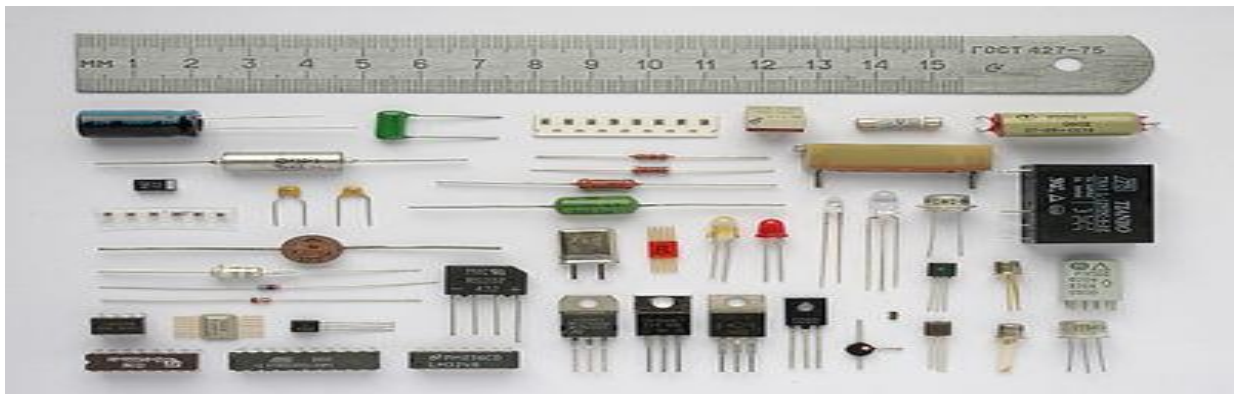

**Consumer Electronics** include products like – Audio Systems, Video Systems, TV (Television), Computer, Laptop, Digital Camera, DVD Players, Home and Kitchen Appliances, GPS, Mobiles Phones etc.

**Communication.** Electronic communication systems connect people around the world. Using telephones, Internet and computers, people in different countries communicate almost instantly. Radios transmit sounds and televisions transmit sounds and pictures great distances. Cellular telephones enable a person to call another person. Within seconds, fax machines send and receive copies of documents over telephone lines/Satellite.

**Information processing.** Scientists, artists, students, government and business workers, and hobbyists at home all rely on computers, Internet to handle huge amounts of information quickly and accurately. Computers solve difficult mathematical problems, maintain vast amounts of data, create complex simulations, and perform a multitude of other tasks that help people in their everyday lives.

**Medicine and research.** Include product like X-ray machines ECG (Electrocardiogram) use radiation to take images of bones and internal organs. Radiation therapy, or radiotherapy, uses X-rays and other forms of radiation to fight cancer. Many hearing-impaired people depend on hearing aids to electrically amplify sound waves.

**Computers** and other electronic instruments provide scientists and other researchers with powerful tools to better understand their area of study. Computers, for example, help scientists design new drug molecules, track weather systems, and test theories about how galaxies and stars develop. Electron microscopes use electrons rather than visible light to magnify specimens 1 million times or more.

**Automation.** Electronic components enable many common home appliances, such as refrigerators, washing machines, and toasters, to function smoothly and efficiently. People can electronically program coffeemakers, lawn sprinklers, and many other products to turn on and off automatically. Microwave ovens heat food quickly by penetrating it with short radio waves produced by a vacuum tube.

**Instrumentation.** Measuring Instruments like CRO, Multimeter, ph-meter, strain gauge, VTVM, Frequency Counter are used in different Laboratory/organisations.

Many automobiles have electronic controls in their engines and fuel systems. Electronic devices also control air bags, which inflate to protect a driver and passengers in a collision.

## 1.2 Define Electronic Emission & different types of Emission.

The Electronics devices depends the movements of free Electrons in an evacuated space. The liberation of electrons from the surface of a metal is known as **Electron Emission**.

- For electron emission, metals are used because they have many free electrons.
- The electrons are free only to transfer from one atom to another within the metal but they cannot leave the metal surface to provide electron emission.
- Thus at the surface of the metal, a free electron encounters forces that prevent it to leave the metal.
- In other words, the metallic surface offer a barrier to free electrons, their kinetic energy increases and is known as surface barrier.
- However, if sufficient energy is given to the free electrons, their kinetic energy increases and thus the electrons will cross over the surface barrier to leave the metal.
- This additional energy required by an electron to overcome the surface barrier of the metal is called *work function* of the metal.

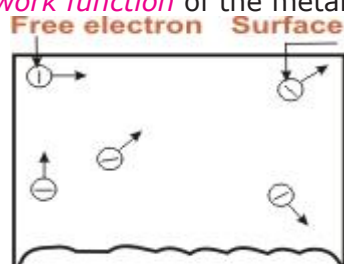

The metallic surface offers a barrier to free electrons and is known as *surface barrier*.

**Work function ( $W_0$ ):** *The amount of additional energy (such as heat energy, energy stored in electric field, light energy or kinetic energy of the electric charges bombarding the metal surface) required to emit an electron from a metallic surface is known as **work function** of that metal.* The minimum energy required by an electron to just escape (i.e. with zero velocity) from metal's surface is called **Work function ( $W_0$ )** of the metal. The work function of pure metals varies (roughly) from **2eV to 6eV**. Its value depends upon the nature of the metal, its purity and the conditions of the surface.

### Different types of Emission:

There are following four principal method of obtaining electron emission from the surface of a metal:

1. Thermionic Emission - (Due to Thermal energy)
2. Field Emission - (Due to application of strong electric field)
3. Secondary Emission - (**due to bombardment of high-speed electrons**)
4. Photo Electric Emission - (by the application of light)

#### 1. Thermionic Emission

The process of electron emission from a metal surface by supplying thermal energy to it is known as **Thermionic emission**.

In this type of emission the electron emission is achieved by heating the electrode to a sufficient temperature (about 2500°C) to enable the free electrons to leave the metal surface. Due to heating the electrons get enough energy that they emit from the surface of that material heat energy is converted into kinetic energy, causing accelerated motion of free electrons and electrons acquire additional energy equal to the work function of the metal. An electron emitted from a hot cathode comes out with a velocity that presents different between the kinetic energy possessed by electron just before emission usually **used in cathode of diode, triode, pentode, CRT** and many other. The higher the temperature, the greater is the emission of electrons. The commonly used materials for electron emission are *tungsten, thoriated tungsten* and *metallic oxides of barium and strontium*.

S.No.	Emitter	Work Function	Operating Temperature
1	Tungsten	4.52 eV	2327°C
2	Thoriated tungsten	2.63 eV	1700°C
3	Oxide-coated	1.1 eV	750°C

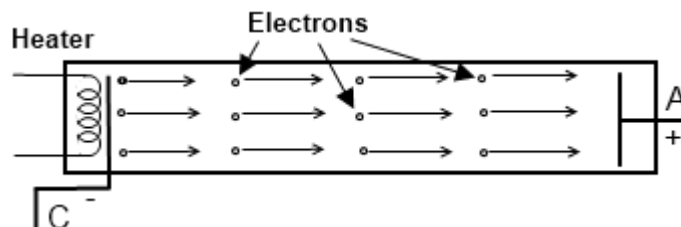

#### 2. Field Emission

The process of electron emission by the application of strong electric field at the surface of a metal is known as **field emission**.

When metal surface is placed in an electric field, the electron rotating in their orbits experience a force due to electrostatic field. Hence the process of electron emission by application of strong electric field at the surface of a metal is called **field emission**. It is also called *cold cathode emission* or *auto-electronic emission*.

### 3. Secondary Emission

Electron emission from a metallic surface by the bombardment of high-speed electrons or other particles is known as **secondary emission**.

When high-speed electrons suddenly strike a metallic surface, they may give some or all of their kinetic energy to the free electrons in the metal. If the energy of the striking electrons is sufficient, it may cause free electrons to escape from the metal surface. This phenomenon is called **secondary emission**. The electrons that strike the metal are called **primary electrons** while the emitted electrons are known as **secondary electrons**. The intensity of secondary emission depends upon the emitter material, mass and energy of the bombarding particles.

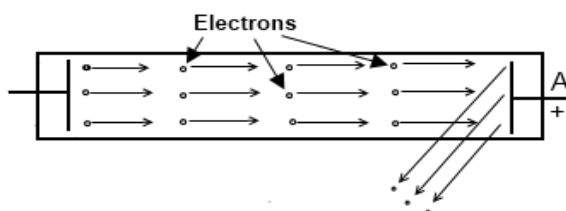

### 4. Photo Electric Emission

Electron emission from a metallic surface by the application of light is known as **photo electric emission**.

When a beam of light strikes the surface of cathode normally **made of potassium, Sodium** the energy of photons of light is transferred to the free electrons of cathode. In this method, the energy of light falling upon the metal surface is transferred to the free electrons within the metal to enable them to leave the surface. The greater the intensity of light beam falling on the metal surface, the greater is the photoelectric emission. The emitted electrons are known as **photo electrons** and the phenomenon is known as **photoelectric emission**. Photo-electric emission is utilised in photo tubes which form the basis of television and sound films.

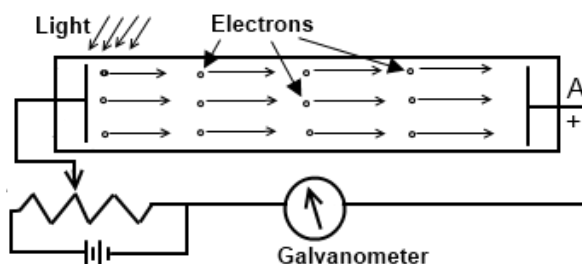

### 1.3 Classification of solid according to electrical conductivity (Conductor, Semiconductor & Insulator) with respect to energy band diagram only.

#### Pre-Knowledge:

**(i) Valence band.** The range of energies (i.e. band) possessed by valence electrons is known as **valence band**. The electrons in the outermost orbit of an atom are known as valence electrons. This band may be completely or partially filled.

#### **(ii) Conduction band.**

The range of energies (i.e. band) possessed by conduction band electrons is known as **conduction band**. Generally, insulators have empty conduction band. On the other hand, it is partially filled for conductors. The free electrons which are responsible for the conduction of current in a conductor are called **conduction electrons**.

**(iii) Forbidden energy gap.** The separation between conduction band and valence band on the energy level diagram is known as **forbidden energy gap**.

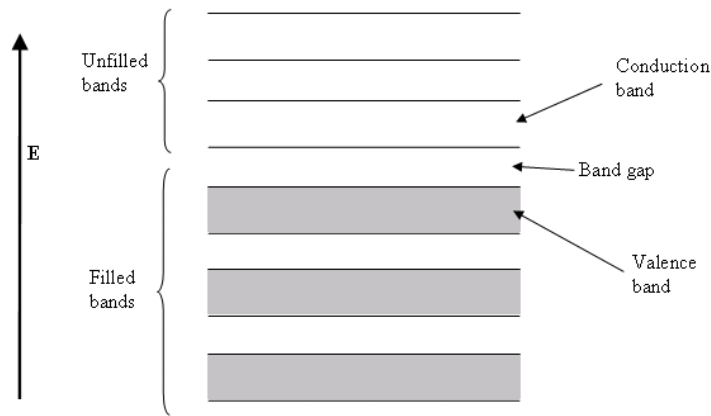

**Fig 1. Energy band diagram**

**Classification:**

**Solid-state materials According to electrical conductivity can be classified into three groups.** Such as:

1. Insulators - Insulators are materials having an electrical conductivity  $\sigma < 10^{-8} S/cm$  (like diamond: 10-14S/cm);
2. Semiconductors - semiconductors have a conductivity  $10^{-8} S/cm < \sigma < 10^3 S/cm$  (for silicon it can range from 10-5S/cm to 103S/cm)
3. Conductors - at last conductors are materials with high conductivities:  $10^3 S/cm < \sigma$  (like silver: 106S/cm.)

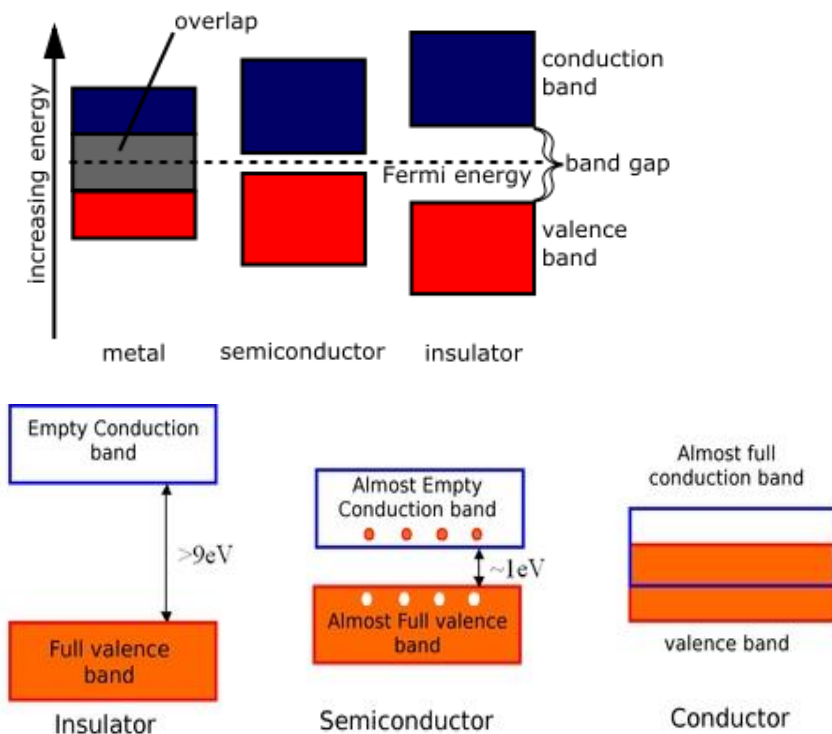

Figure 2 : Representation of energy bands

**(i) Insulators.** Insulators (e.g. wood, glass, plastics, rubber etc.) are those substances which do not allow the passage of electric current through them. In terms of energy band, the valence band is full while the conduction band is empty as shown in Fig 2. Further, the energy gap between valence and conduction bands is very large (**15 eV**). Therefore, a very high electric field is required to push the valence electrons to the conduction band. For this reason, the electrical conductivity of such materials is extremely small. At room

temperature, the valence electrons of the insulators do not have enough energy to cross over to the conduction band. However, when the temperature is raised, some of the valence electrons may acquire enough energy to cross over to the conduction band. Hence, the resistance of an insulator decreases with the increase in temperature *i.e.* an insulator has **negative temperature coefficient of resistance**.

(ii) **Conductors.** Conductors (e.g. copper, aluminum) are those substances which easily allow the passage of electric current through them. It is because there are a large number of free electrons available in a conductor. In terms of energy band as in Fig 2, the valence and conduction bands overlap each other due to this overlapping; a slight potential difference across a conductor causes the free electrons to constitute electric current.

(iii) **Semiconductors.** Semiconductors (e.g. germanium, silicon etc.) are those substances whose electrical conductivity lies in between conductors and insulators. In terms of energy band, the valence band is almost filled and conduction band is almost empty in fig 2. Further, the energy gap between valence and conduction bands is very small. The semiconductor has :

- (a) Filled valence band
- (b) Empty conduction band
- (c) Small energy gap or forbidden gap ( 1 eV) between valence and conduction bands.
- (d) Semiconductor virtually behaves as an insulator at low temperatures. However, even at room temperature, some electrons cross over to the conduction band, imparting little conductivity (i.e. conductor).

### 1.3 Discuss Intrinsic & Extrinsic Semiconductor.

#### Intrinsic Semiconductor

A semiconductor in an extremely pure form is known as an **intrinsic semiconductor**.

In this case the holes in the valence band are vacancies created by electrons that have been thermally excited to the conduction band and hole-electron pairs are created. When electric field is applied across an intrinsic semiconductor, the current conduction takes place by two processes, namely; by **free electrons** and **holes** as shown in Fig 3. The free electrons are produced due to the breaking up of some covalent bonds by thermal energy. At the same time, holes are created in the covalent bonds. Under the influence of electric field, conduction through the semiconductor is by both free electrons and holes. Therefore, the total current inside the semiconductor is the sum of currents due to free electrons and holes. This creates new holes near the positive terminal which again drift towards the negative terminal.

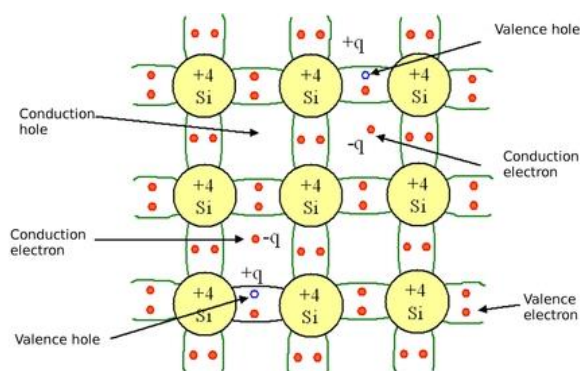

Figure 3 : Diagram showing the electronic bonds in an intrinsic semiconductor (Si)

#### Extrinsic Semiconductor

**An extrinsic semiconductor is a semiconductor doped by addition of small amount impurity which is able to change its electrical properties (conduction), making it suitable for electronic applications (diodes, transistors, etc.) or optoelectronic applications (light emitters and detectors). This is achieved by adding a small amount of suitable impurity (having 3 or 5 valence electron) to a semiconductor (having 4 valence electron). It is then called impurity or extrinsic semiconductor.**

- The process of adding impurities to a semiconductor is known as *doping*. The purpose of adding impurity is to increase either the number of free electrons or holes in the semiconductor crystal.
  - If a penta valent impurity (having 5 valence electrons) is added to the semiconductor, a large number of **free electrons** are produced in the semiconductor.
  - If a trivalent impurity (having 3 valence electrons) is added to the semiconductor, large number of **holes** are produced in the semiconductor crystal.
  - Depending upon the type of impurity added, extrinsic semiconductors are classified into:
    - (i) *n*-type semiconductor
    - (ii) *p*-type semiconductor
- (i) *n*-type Semiconductor

When a small amount of pentavalent impurity is added to a pure semiconductor, it is known as **n-type semiconductor**.

The addition of pentavalent impurity provides a large number of free electrons in the semiconductor crystal. Typical examples of pentavalent impurities are *arsenic*, *antimony*, *Bismuth* and *Phosphorous* etc. Such impurities which produce *n*-type semiconductor are known as *donor impurities* because they donate or provide free electrons to the semiconductor crystal.

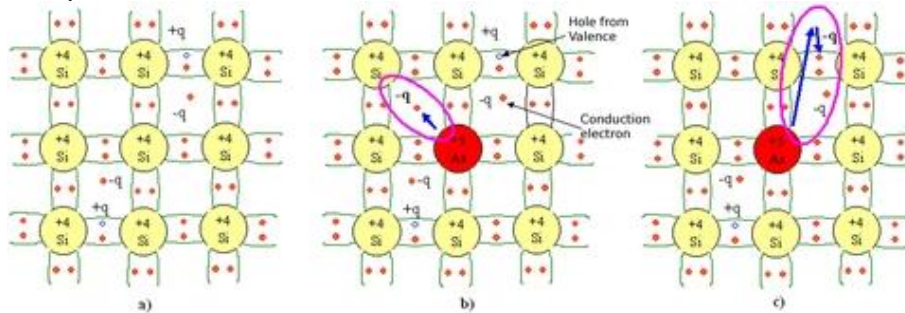

Figure 4 : Schematic representation of electronic bonds in a Silicon crystal doped with Arsenic As (*n* doping)

- Electrons are said to be the majority carriers whereas holes are the minority carriers.

(ii) *p*-type Semiconductor

When a small amount of trivalent impurity is added to a pure semiconductor, it is called **p-type Semiconductor**.

The addition of trivalent impurity provides a large number of holes in the semiconductor. Typical examples of trivalent impurities are *gallium*, *indium*, *boron* etc. Such impurities which produce *p*-type semiconductor are known as *acceptor impurities* because the holes created can accept the electrons fig 5.

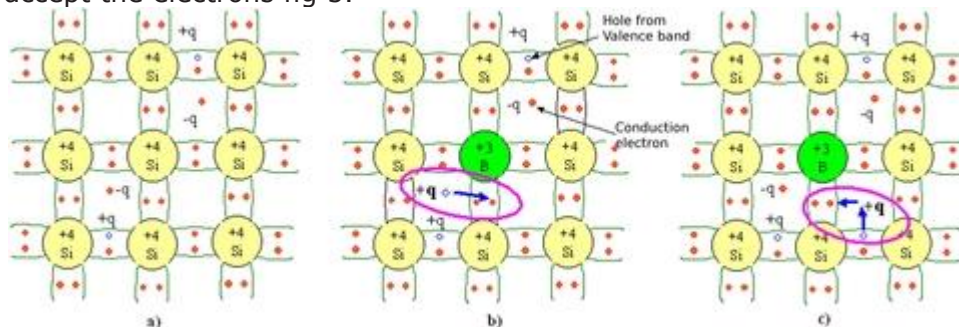

Figure 5 : schematic representation of a Si crystal doped with boron (B)

Electrons are said to be the minority carriers whereas holes are the majority carriers.

1.4 *Explain the difference between vacuum tube & semiconductor.*



Figure 6: Vacuum tubes

**Vacuum Tubes:**

**Advantages**

1. Superior sound quality.
2. Can handle large currents
3. Tolerant of large overloads and voltage spikes.
4. Characteristics highly independent of temperature, greatly simplifying biasing.
5. Wider dynamic range than transistors circuits, due to higher operating voltages and overload tolerance.
6. Capacitive coupling can be done with small, high-quality film capacitors, due to inherently high-impedances of tube circuits.
7. Operation is usually in Class A or Class AB, minimizing crossover notch distortion.
8. Tubes can be relatively easily replaced by user.

**Disadvantages**

1. Bulky(Larger in Size), hence not suitable for portable products
2. Higher operating voltages required.
3. High power consumption; needs heater supply that generates waste heat and yields lower efficiency, notably for small-signal circuits.
4. Glass tubes are fragile, compared to metal transistors.
5. Cathode electron-emitting materials are used up in operation.
6. High-impedance devices that need impedance matching transformer for low-impedance loads, like speakers; however, the magnetic cushion provided by an output transformer prevents the output tubes from blowing up.
7. Sometimes higher cost than equivalently powered transistors.
8. Complicated in manufacturing process.

**Transistors:**

**Advantages**

1. Usually smaller size, lower cost and longer life.
2. Can handle small current
3. Can be combined in the millions on one cheap die to make an integrated circuit, whereas tubes are limited to at most three functional units per glass bulb.
4. Lower power consumption, less waste heat, and high efficiency than equivalent tubes, especially in small-signal circuits.
5. Can operate on lower-voltage supplies for greater safety, lower costs, tighter clearances.
6. Usually more physical ruggedness than tubes (depends upon construction).

**Disadvantages**

1. Tendency toward higher distortion
2. Complex circuits and considerable negative feedback required for low distortion.
3. Large unit-to-unit manufacturing tolerances and unreliable variations in key parameters, such as gain and threshold voltage.
4. Device parameters vary considerably with temperature, complicating biasing and increasing likelihood of thermal runaway.
5. Cooling is less efficient than with tubes, because lower operating temperature is required for reliability. Tubes prefer hot; transistors do not. Massive, expensive and unwieldy heat sinks are always required for power transistors, yet they are not always effective



(power output transistors still blow up; whereas, tubes fade down gracefully over time with warning.)

6. Less tolerant of overloads and voltage spikes than tubes.
7. Capacitive coupling usually requires high-value electrolytic capacitors, which give audibly and measurably inferior performance at audio frequency extremes.
8. Greater tendency to pick up radio frequency interference and self-oscillate to the point of self-destruction, due to rectification by low-voltage diode junctions or slew-rate effects.
9. Maintenance more difficult; devices are not easily replaced by user.

### 1.5 State basic concept of Integrated Circuits (I.C) & its use.



Figure 7: Integrated Circuits

An integrated circuit (IC), sometimes called a *chip* or *microchip*, is a **semiconductor** wafer on which thousands or millions of tiny resistors, capacitors, and **transistors** are fabricated. An IC can function as an **amplifier**, **oscillator**, timer, counter, computer **memory**, or microprocessor. A particular IC is categorized as either linear **analog** or **digital**, depending on its intended application. IC's are of Linear, digital and mixed types

*Linear ICs* have continuously variable output (theoretically capable of attaining an infinite number of states) that depends on the input signal level. As the term implies, the output signal level is a linear function of the input signal level. Linear ICs are used as audio-frequency (**AF**) and radio-frequency (**RF**) amplifiers. The *operational amplifier* (op amp) is a common device in these applications.

*Digital ICs* operate at only a few defined levels or states, rather than over a continuous range of signal amplitudes. These devices are used in computers, computer networks, modems, and frequency counters. The fundamental building blocks of digital ICs are **logic gates**, which work with binary data, that is, signals that have only two different states, called low (logic 0) and high (logic 1).

### Applications and Uses of Integrated Circuits

The advantages of Integrated Circuits are:

1. Very small size: Hundred times smaller than the discrete circuits.
2. Lesser weight: As large number of components can be packed into a single chip, weight is reduced
3. Reduced cost: The mass production technique has helped to reduce the price,
4. High reliability: Due to absence of soldered connection, few interconnections and small temperature rise failure rate is low.
5. Low power requirement: As the size is small power consumption is less.
6. Easy replacement: In case of failure chip can easily be replaced.

Linear IC's also known as analog Integrated circuits are:

1. Power amplifiers
2. Small-signal amplifiers
3. Operational amplifiers
4. Microwave amplifiers
5. RF and IF amplifiers
6. Voltage comparators

7. Multipliers
8. Radio receivers
9. Voltage regulators

Digital IC's are mostly used in computers. They are also referred as switching circuits because their input and output voltages are limited to two levels - high and low i.e. binary. They include:

1. Flip-flops
2. Logic gates
3. Timers
4. Counters
5. Multiplexers
6. Calculator chips
7. Memory chips
8. Clock chips
9. Microprocessors
10. Microcontrollers
11. Temperature sensors

Mixed type applications - cars (automotive controls), televisions, computers, microwaves, portable devices like laptops, MP3, play stations, cameras, cellular phones to ship equipments, aero planes, space craft's. These are also used in switching telephone circuits and data processing. They also found applications in military equipments. The most common application of IC is digital watch which tells hour, second, minute, day and month. Another common but important application is scientific calculator which can perform basic functions like addition, subtraction, multiplication and division as well as complex functions like square root, cube, permutations, combinations , trigonometric functions, etc

**Chapter Review Questions:**

1. Define Electronics & its application.
2. Define work function.
3. Define Electronic Emission & different types of Emission.
4. Explain Conductor, Semiconductor & Insulator with respect to energy band diagram only.
5. Define doping.
6. Define energy gap & valence electrons
7. Discuss Intrinsic Semiconductor.
8. Discuss Extrinsic Semiconductor.
9. Explain the difference between vacuum tube & semiconductor.
10. State basic concept of integrated circuits (I.C) & its use.
11. Define acceptor & donor atom
12. List different types of Impurity.

## Chapter-2

### 2.1 Define Rectifier & state its use.

The conversion of bidirectional alternating current (a.c.) into unidirectional direct current (d.c.) is called **rectification**. Electronic devices can convert a.c. power into d.c. power with very high efficiency.

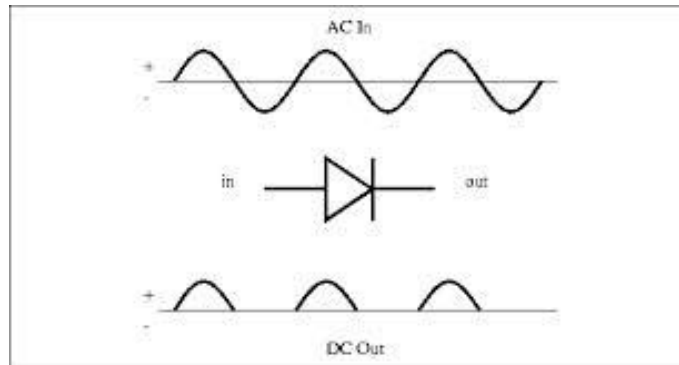

**Example-Diodes** : Diodes are useful electrical components for rectification purposes. Diodes are used in many applications like the following.

- Converting AC power from the 60Hz line into DC power for radios, televisions, telephone answering machines, computers, and many other electronic devices.
- Converting radio frequency signals into audible signals in radios.
- used as rectifier in DC Power Supplies.
- In Demodulation or Detector Circuits.
- In clamping networks used as DC Restorers
- In clipping circuits used for waveform generation.
- As switches in digital logic circuit

#### 2.1.1 Rectifying diode

Review of P-type and N-type semiconductor junction of P-type & N-type i.e. PN junction Barrier voltage, depletion region, Junction Capacitance.

A p-n junction is a boundary or interface between two types of semiconductor material, **p-type** and **n-type**, inside a single crystal of **semiconductor**. p-n junctions are elementary "building blocks" of most **semiconductor electronic devices** such as **diodes, transistors, solar cells, LEDs**, and **integrated circuits**. After joining p-type and n-type semiconductors, electrons from the n region near the p-n interface tend to diffuse into the p region. The regions nearby the p-n interfaces lose their neutrality and become charged, forming the **space charge region** or **depletion layer**

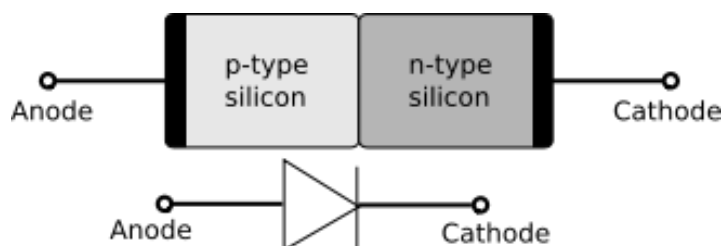

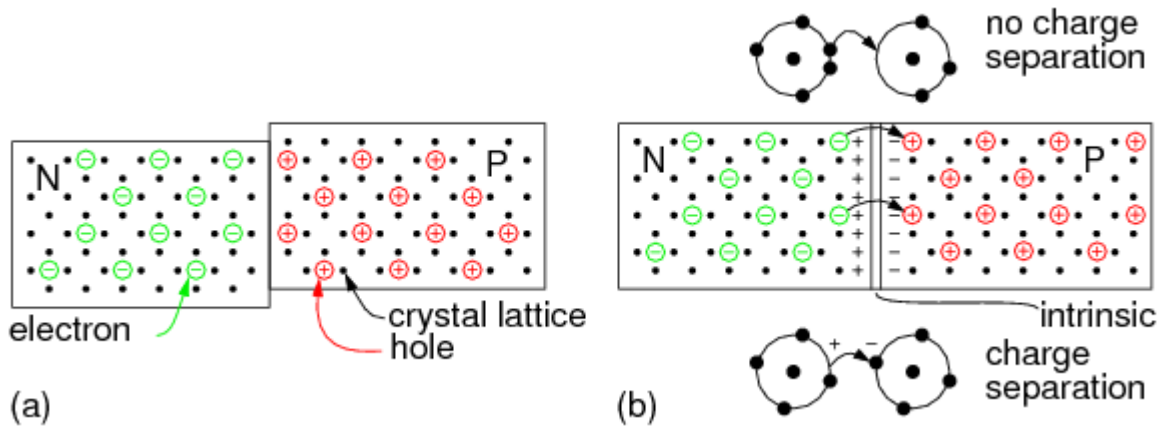
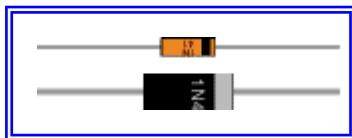

Fig 8 (a) Blocks of P and N semiconductor in contact have no exploitable properties. (b) Single crystal doped with P and N type impurities develops a potential barrier.

This separation of charges at the PN junction constitutes a potential barrier. This potential barrier must be overcome by an external voltage source to make the junction conduct.

## PN Junction Diodes

Example:



Circuit symbol:

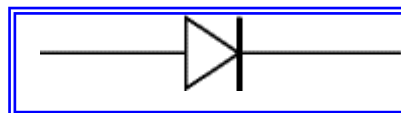

### Function

Diodes allow electricity to flow in only one direction. The arrow of the circuit symbol shows the direction in which the current can flow.

### Forward Voltage Drop

When a forward voltage is applied to diode, a small voltage experiences across a conducting diode, it is called the **forward voltage drop** and is about 0.7V for all normal diodes which are made from silicon. The forward voltage drop of a diode is almost constant whatever the current passing through the diode so they have a very steep characteristic (current-voltage graph).

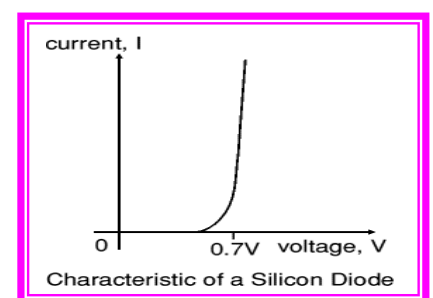

### Reverse Voltage

When a reverse voltage is applied a perfect diode does not conduct, but all real diodes leak a very tiny current of a few  $\mu\text{A}$  or less. This can be ignored in most circuits because it will be very much smaller than the current flowing in the forward direction. However, all diodes have a **maximum reverse voltage** (usually 50V or more) and if this is exceeded the diode will fail and pass a large current in the reverse direction, this is called **breakdown**.

Ordinary diodes can be split into two types: [Signal diodes](#) which pass small currents of 100mA or less and [Rectifier diodes](#) which can pass large currents. In addition there are other types of diodes as such : [LEDs](#), [Zener diodes](#) ,Tunnel diode,PIN diode,Photo diode and Varicap diode etc.

## Practical Knowledge:

### Connecting and soldering

Diodes must be connected the correct way round, the diagram may be labeled **a** or **+** for anode and **k** or **-** for cathode (yes, it really is k, not c, for cathode!). The cathode is marked by a line painted on the body. Diodes are labeled with their code in small print, you may need a magnifying glass to read this on small signal diodes!

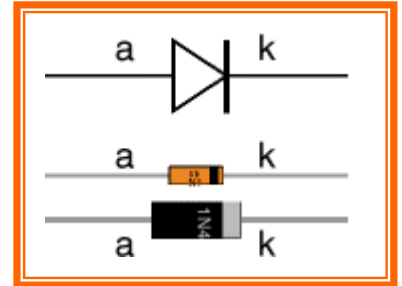

Small **signal diodes** can be damaged by heat when soldering, but the risk is small unless you are using a **germanium diode** (codes beginning OA...) in which case you should use a heat sink clipped to the lead between the joint and the diode body. A standard crocodile clip can be used as a heat sink.

### Signal diodes (small current)

Signal diodes are used to process information (electrical signals) in circuits, so they are only required to pass small currents of up to 100mA.

General purpose signal diodes such as the 1N4148 are made from silicon and have a forward voltage drop of 0.7V.

**Germanium diodes** such as the OA90 have a lower forward voltage drop of 0.2V and this makes them suitable to use in radio circuits as detectors which extract the audio signal from the weak radio signal.

For general use, where the size of the forward voltage drop is less important, silicon diodes are better because they are less easily damaged by heat when soldering, they have a lower resistance when conducting, and they have very low leakage currents when a reverse voltage is applied.

**Biasing of Diode:** The process of applying an external voltage is called as "biasing".

### Pre Knowledge:

**Zero Bias:** When no external voltage potential is applied to the PN junction diode called Zero Biased Junction Diode. However if the diodes terminals are shorted together, a few holes (majority carriers) in the P-type material with enough energy to overcome the potential barrier will move across the junction against this barrier potential. This is known as the "Forward Current" and is referenced as  $I_F$ . Likewise, holes generated in the N-type material (minority carriers) and move across the junction in the opposite direction. This is known as the "Reverse Current" and is referenced as  $I_R$ . This transfer of electrons and holes back and forth across the PN junction is known as diffusion, as shown Fig 9.

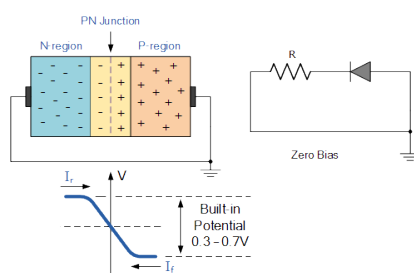

Fig 9: Zero Bias

But how ever there are two ways in which we can bias a pn junction diode.

- 1) Forward bias
- 2) Reverse bias

Forward Bias – The voltage potential is connected positive, (+ve) to the P-type material and negative, (-ve) to the N-type material across the diode which has the effect of **Decreasing** the PN junction diodes's width.

Reverse Bias – The voltage potential is connected negative, (-ve) to the P-type material and positive, (+ve) to the N-type material across the diode which has the effect of **Increasing** the PN junction diode's width.

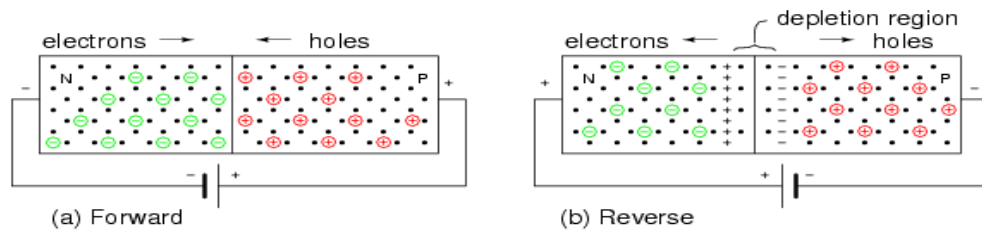

### 2.1.2 Forward & Reverse bias & V-I characteristics of PN junction Diode

#### Forward Biased PN Junction Diode

When a diode is connected in a **Forward Bias** condition, a negative voltage is applied to the n-type material and a positive voltage is applied to the p-type material. If this external voltage becomes greater than the value of the potential barrier, approx. 0.7 volts for silicon and 0.3 volts for germanium, the potential barriers opposition will be overcome and current will start to flow.

#### Forward Characteristics Curve for a Junction Diode

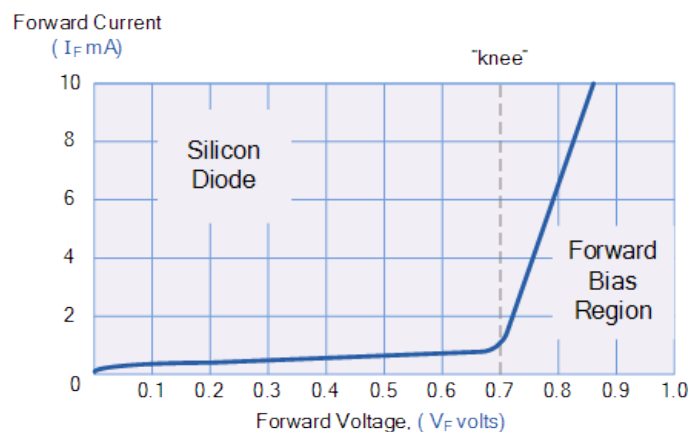

The application of a forward biasing voltage on the junction diode results

- the depletion layer becoming very thin and narrow which represents a low impedance path through the junction thereby allowing high currents to flow.
- The point at which this sudden increase in current takes place is represented on the static I-V characteristics curve above as the "knee" point.

## Reduction in the Depletion Layer due to Forward Bias

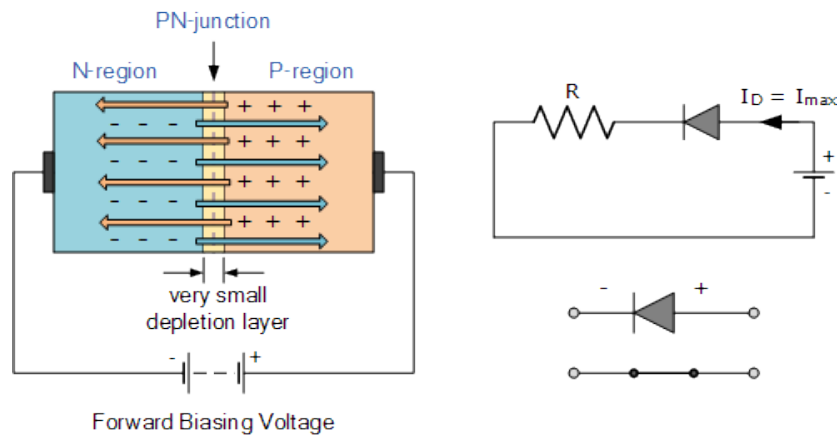

## Reverse Biased PN Junction Diode

When a diode is connected in a **Reverse Bias** condition, a positive voltage is applied to the N-type material and a negative voltage is applied to the P-type material. The positive voltage applied to the N-type material attracts electrons towards the positive electrode and away from the junction, while the holes in the P-type end are also attracted away from the junction towards the negative electrode. Thus

- the depletion layer grows wider due to a lack of electrons and holes and presents a high impedance path, almost an insulator.
- The result is that a high potential barrier is created thus preventing current from flowing through the semiconductor material.
- a high resistance value to the PN junction and practically zero current flows through the junction diode with an increase in bias voltage. However, a very small **leakage current** does flow through the junction which can be measured in microamperes, ( $\mu A$ ).

## Increase in the Depletion Layer due to Reverse Bias

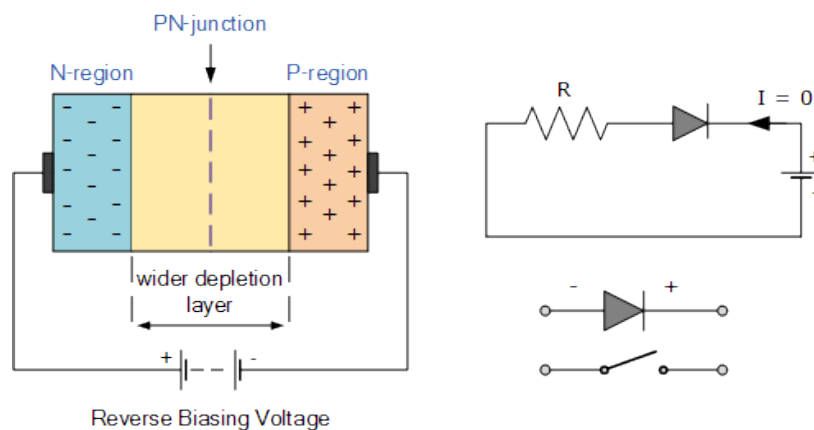

## Reverse Characteristics Curve for a Junction Diode

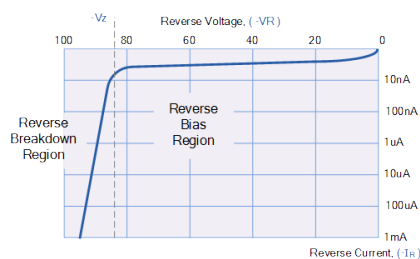

## Junction Diode Symbol and Static I-V Characteristics.

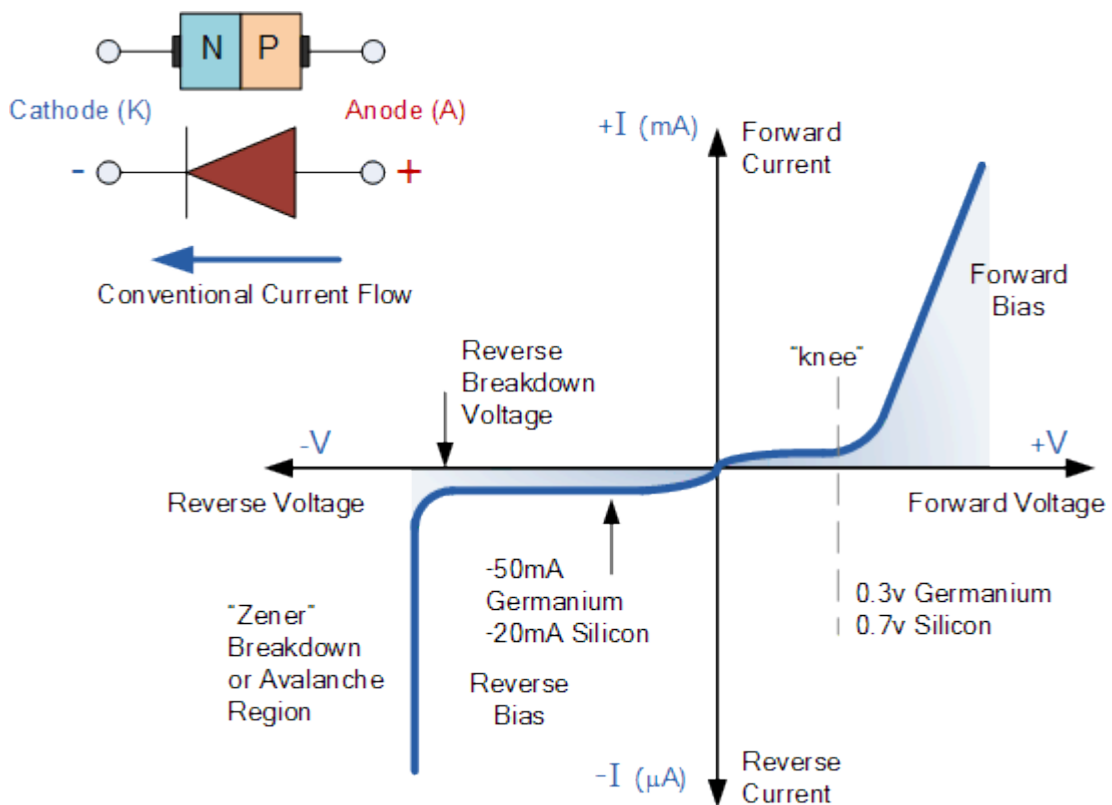

### Junction capacitance

All PN junction diodes exhibit a junction capacitance. The depletion region is the dielectric spacing between the two plates which are effectively formed at the edge of the depletion region and the area with majority carriers.

Any variation of the charge within a p-n diode with an applied voltage variation yields a capacitance which must be added to the circuit model of a p-n diode. The capacitance associated with the charge variation in the depletion layer is called the **junction** capacitance, while the capacitance associated with the excess carriers in the quasi-neutral region is called the **diffusion** capacitance.

- Expressions for the capacitances are obtained by calculating the change in charge for a change in applied voltage, or:

$$C = \frac{dQ}{dV}$$

The actual value of capacitance being dependent upon the reverse voltage which causes the depletion region to change (increasing reverse voltage increases the size of the depletion region and hence decreases the capacitance).

This fact is used in **varactor or varicap diodes** to good effect, but for many other applications, especially RF applications this needs to be minimised. As the capacitance is of importance it is specified. The parameter is normally detailed as a given capacitance (in pF) at a given voltage or voltages. Also special low capacitance diodes are available for many RF applications



## Junction Diode Summary

The PN junction region of a **Junction Diode** has the following important characteristics:

- Semiconductors contain two types of mobile charge carriers, **Holes** and **Electrons**.
- The holes are positively charged while the electrons negatively charged.
- A semiconductor may be doped with donor impurities such as Antimony (N-type doping), so that it contains mobile charges which are primarily electrons.
- A semiconductor may be doped with acceptor impurities such as Boron (P-type doping), so that it contains mobile charges which are mainly holes.
- The junction region itself has no charge carriers and is known as the depletion region.
- The junction (depletion) region has a physical thickness that varies with the applied voltage.
- When a diode is **Zero Biased** no external energy source is applied and a natural **Potential Barrier** is developed across a depletion layer which is approximately 0.5 to 0.7v for silicon diodes and approximately 0.3 of a volt for germanium diodes.
- When a junction diode is **Forward Biased** the thickness of the depletion region reduces and the diode acts like a short circuit allowing full current to flow.
- When a junction diode is **Reverse Biased** the thickness of the depletion region increases and the

### 2.1.2 Specifications:-(Definition)

Forward voltage drop, Reversed saturation current, maximum forward current ,power dissipation

Package view of diodes of different power ratings(to be shown during practical hours)

The list below provides details of the various diode characteristics, and diode parameters found in the datasheets and specifications for diodes.

- **Semiconductor material:** Silicon is the most widely used material as it offers high levels of performance for most applications and it offers low manufacturing costs. The other material that is used is germanium. Germanium materials are generally reserved for more specialist diodes.
- **Forward voltage drop (Vf):** The voltage across a PN junction diode arise for two reasons. The first of the nature of the semiconductor PN junction and results from the turn-on voltage mentioned above. This voltage enables the depletion layer to be overcome and for current to flow. The second arises from the normal resistive losses in the device. It is the instantaneous forward voltage that a pn junction can conduct without damage the pn junction.
- **Peak Inverse Voltage (PIV):** It is the maximum voltage a diode can withstand in the reverse direction without damage to pn junction.
- **Maximum forward current:** It is the maximum instantaneous forward current that a pn junction can conduct without damage the pn junction When designing a circuit that passes any levels of current it is necessary to ensure that the maximum current levels for the diode are not exceeded. As the current levels rise, so additional heat is dissipated and this needs to be removed.
- **Maximum power rating:** It is the maximum power that can be dissipated without damage the pn junction.

### 2.2 Zener Diode :Construction (reference to doping level)

2.2.2 Symbol ,circuit diagram for characteristics (forwarded & reversed

## Zener diodes



## Circuit symbol:

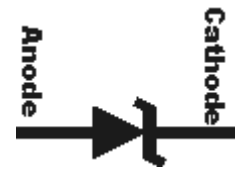

Zener diodes or as they may sometimes be called, reference diodes operate like an ordinary diode in the forward bias direction. They have the normal turn on voltage of 0.6 volts for a silicon diode. However in the reverse direction their operation is rather different. Zener diodes are used to maintain a fixed voltage. They are designed to 'breakdown' in a reliable and non-destructive way so that they can be used **in reverse** to maintain a fixed voltage across their terminals. The diagram shows how they are connected, with a resistor in series to limit the current.

Zener diodes can be distinguished from ordinary diodes by their code and breakdown voltage which are printed on them. Zener diode codes begin BZX... or BZY... Their breakdown voltage is printed with V in place of a decimal point, so 4V7 means 4.7V for example. Some of Zener diodes are rated by their breakdown voltage and maximum power:

- The minimum voltage available is 2.7V.
- Power ratings of 400mW and 1.3W are common.

### Zener v-i characteristic

The v-i characteristic of the Zener to voltage reference diode is the key to its operation. In the forward direction, the diode performs like any other, but it is in the reverse direction where its specific performance parameters can be utilised.

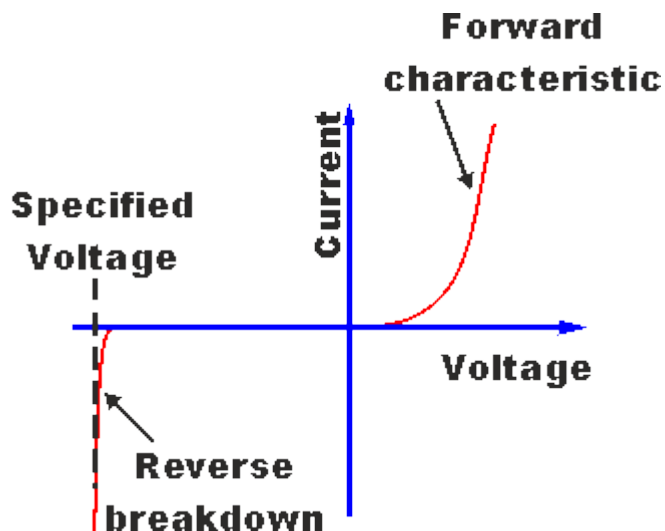

Fig 10 Zener diode characteristic

Although the voltage reference diode is normally referred to as a Zener diode, there are two different breakdown mechanisms that can occur:

- **Zener effect:** This effect predominates below 5.5 volts.
- **Impact ionisation:** This effect predominates above 5.5 volts.

### Simple Zener diode circuit for voltage regulator

When used in a regulator circuit, the Zener diode must have the current entering it limited. If a perfect voltage source was placed across it, then it would draw excessive current once the breakdown voltage had been reached. To overcome this the Zener diode must be driven by a current source. This will limit the current to the chosen value. The value of the series resistor is simple to calculate. It is simply the voltage across the resistor, divided by the current required. The level of Zener current can be chosen to suit the circuit and the Zener diode used.

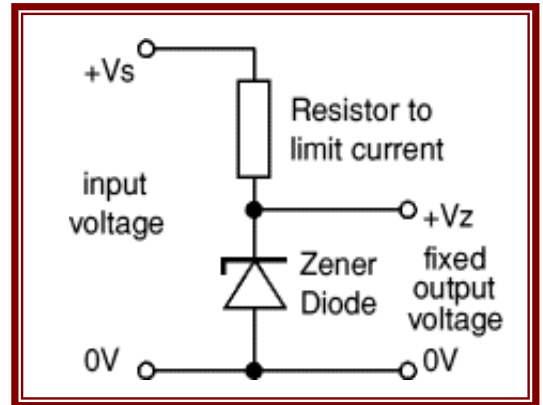

Fig 12 Simple circuit of a Zener diode shunt regulator

### Application of Zener

Used in Voltage Stabilizer, Clipper Circuit, Reference voltage limiter circuits

#### 2.2.3 Differences between avalanche & zener breakdown?

##### Zener breakdown:

In Zener breakdown the electrostatic attraction between the negative electrons and a large positive voltage is so great that it pulls electrons out of their covalent bonds and away from their parent atoms. ie Electrons are transferred from the valence to the conduction band. In this situation the current can still be limited by the limited number of free electrons produced by the applied voltage so it is possible to cause Zener breakdown without damaging the semiconductor. The important points are:

- Both sides of PN junction are heavily doped
- Depletion layer is narrow
- A strong electric field is produced
- Large number of holes and electrons are produced
- Zener current is independent of applied voltage

##### Avalanche breakdown

Avalanche breakdown occurs when the applied voltage is so large that electrons that are pulled from their covalent bonds are accelerated to great velocities. These electrons collide with the silicon atoms and knock off more electrons. These electrons are then also accelerated and subsequently collide with other atoms. Each collision produces more electrons which leads to more collisions etc. The current in the semiconductor rapidly increases and the material can quickly be destroyed. The important points are:

- Both sides of PN junction are lightly doped
- Depletion layer is large
- Electric field is not so strong
- Electron hole pairs are generated
- Charge carriers acquire energy from the applied potential

### 2.3. (i)Special Diodes :

#### Tunnel Diode

The tunnel diode is a form of very fast semiconductor diode that can operate well into the microwave radio frequency region.

#### Tunnel diode circuit symbol

Despite the operation of the tunnel diode, its circuit symbol as shown in fig. 13 is based on that for the standard diode, but has 'tails' added to the bar element of the symbol to differentiate it from other forms of PN junction diode.



Fig 13-Tunnel diode circuit symbol

#### Tunnel diode theory basics

Tunneling is an effect that is caused by quantum mechanical effects when electrons pass through a potential barrier. It can be visualized in very basic terms by them "tunneling" through the energy barrier. The tunneling only occurs under certain conditions. It occurs within tunnel diodes because of the very high doping levels employed.

At reverse bias, the electrons tunnel from the valence band in the p-type material to the conduction band in the n-type material, and the level of the current increase monotonically. The characteristic curve for a tunnel diode shows an area of negative resistance. When forward biased the current in the diode rises at first, but later it can be seen to fall with increasing voltage, before finally rising again.

It is also interesting to note that current also flows in the reverse direction - the reverse breakdown voltage is actually zero and the diode conducts in the reverse direction. The characteristics near the origin are virtually symmetrical.

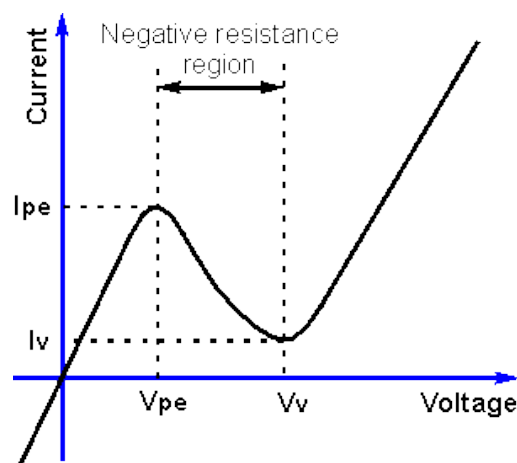

Fig 14 Tunnel diode VI characteristic

The reason for this is that there are a number of different components to forming the overall curve.

- **Normal diode current:** This is the 'normal' current that would flow through a PN junction diode.
- **Tunneling current:** This is the current that arises as a result of the tunneling effect.

- **Excess current:** This is a third element of current that contributes to the overall current within the diode. It results from what may be termed excess current that results from tunneling through bulk states in the energy gap, and means that the valley current does not fall to zero.

### Advantages

- **Very high speed:** The high speed of operation means that the tunnel diode can be used for microwave RF applications.
- **Longevity:** Studies have been undertaken of the tunnel diode and its performance has been shown to remain stable over long periods of time, where other semiconductor devices may have degraded.

### Disadvantages

- **Reproducibility:** It has not been possible to make the tunnel diode with as reproducible performance to the levels often needed.
- **Low peak to valley current ratio:** The negative resistance region and the peak to valley current is not as high as is often required to produce the levels of performance that can be attained with other devices.

### Applications

Oscillator circuits: Tunnel diodes can be used as high frequency oscillators as the transition between the high electrical conductivity is very rapid. They can be used to create oscillation as high as 5Gz. Even they are capable of creating oscillation up to 100 GHz in appropriate digital circuits.

Used in microwave circuits: Normal diode transistors do not perform well in microwave operation. So, for microwave generators and amplifiers tunnel diodes are used. In microwave waves and satellite communication equipments they were used widely, but now a day's their uses are decreasing rapidly as transistor for working in wave frequency area available in market.

Resistant to nuclear radiation: Tunnel diodes are resistant to the effects of magnetic fields, high temperature and radioactivity. That's why these can be used in modern military equipment. These are used in nuclear magnetic resonance machines also. But the most important field of its use is satellite communication equipments.

**(ii) Optical Diodes :-** LED, IRLED & photodiode (Symbol, working principle & applications of each)

### Light emitting diode (LED)

A light emitting diode (LED) is known to be one of the best [optoelectronic devices](#). The device is capable of emitting a fairly narrow bandwidth of visible or invisible light when its internal diode junction attains a forward electric current or voltage. The visible lights that an LED emits are usually *orange, red, yellow, or green*. The invisible light includes the infrared light.

We know that a P-N junction can convert the absorbed light energy into its proportional electric current. The same process is reversed here. That is, the P-N junction emits light when energy is applied on it. This phenomenon is generally called electro luminescence, which can be defined as the emission of light from a semi-conductor under the influence of an electric field. The charge carriers recombine in a forward P-N junction as the electrons cross from the N-region and recombine with the holes existing in the P-region. Free electrons are in the conduction band of energy levels, while holes are in the valence energy band. Thus the energy level of the holes will be lesser than the energy levels of the electrons. Some part of the energy must be dissipated in order to recombine the electrons and the holes. This energy is emitted in the form of heat and light.

The electrons dissipate energy in the form of heat for silicon and germanium diodes. But in Gallium-Arsenide-phosphorous (GaAsP) and Gallium-phosphorous (GaP) semiconductors, the electrons dissipate energy by emitting photons.

### LED Circuit Symbol

The circuit symbol of LED consists of two arrow marks which indicate the radiation emitted by the diode.



The constructional diagram of a LED is shown below.

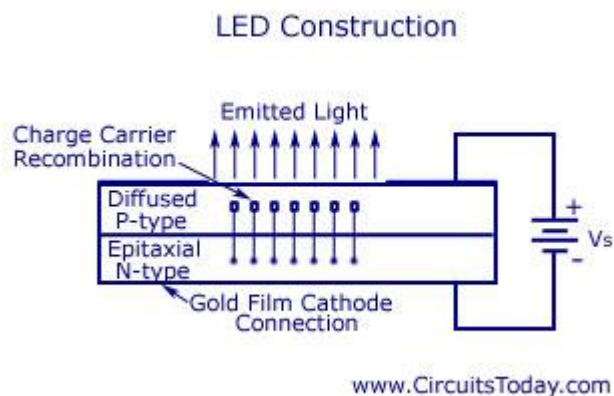
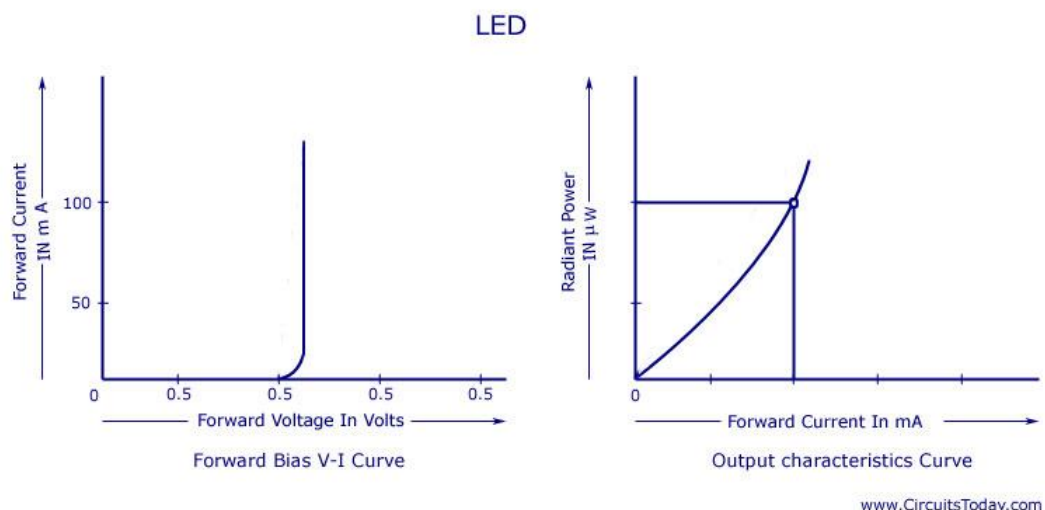

Fig. LED Construction

### LED Characteristics



LED Characteristics

The forward bias Voltage-Current (V-I) curve and the output characteristics curve is shown in the figure above.

## LED as an Indicator

The circuit shown below is one of the main applications of LED. The circuit is designed by wiring it in inverse parallel with a normal diode, to prevent the device from being reverse biased. The value of the series resistance should be half, relative to that of a DC circuit.

### LED As An Indicator

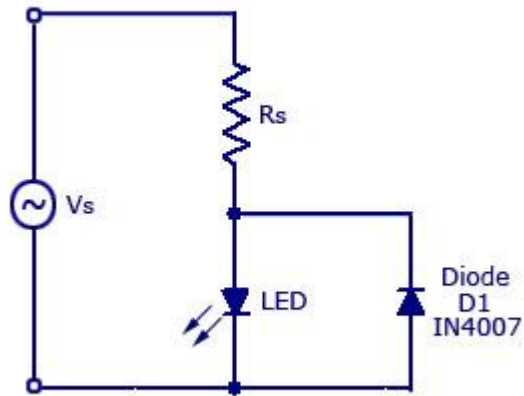

www.CircuitsToday.com

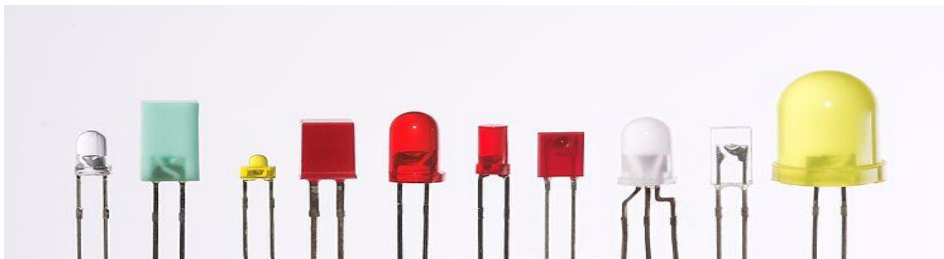

### Advantages of LED

- Very low voltage and current are enough to drive the LED.
- Voltage range – 1 to 2 volts.
- Current – 5 to 20 milli amperes.
- Total power output will be less than 150 milli watts.
- The response time is very less – only about 10 nanoseconds.
- The device does not need any heating and warm up time.
- Miniature in size and hence light weight.
- Have a rugged construction and hence can withstand shock and vibrations.
- An LED has a life span of more than 20 years.

### Disadvantages

- A slight excess in voltage or current can damage the device.
- The device is known to have a much wider bandwidth compared to the laser.
- The temperature depends on the radiant output power and wavelength.

### Photodiodes

A **photodiode** is a semiconductor device that converts [light](#) into [current](#). The current is generated when photons are absorbed in the photodiode. A small amount of current is also produced when no light is present.

A *photodiode* is a diode optimized to produce an electron current flow in response to irradiation by ultraviolet, visible, or infrared light. Silicon is most often used to fabricate photodiodes; though, germanium and gallium arsenide can be used. The junction through which light enters the semiconductor must be thin enough to pass most of the light on to the active region (depletion region) where light is converted to electron hole pairs.

In Figure 15 shallow P-type diffusion into an N-type wafer produces a PN junction near the surface of the wafer. The P-type layer needs to be thin to pass as much light as possible. A heavy N+ diffusion on the back of the wafer makes contact with metalization. The top metalization may be a fine grid of metallic fingers on the top of the wafer for large cells. In small photodiodes, the top contact might be a sole bond wire contacting the bare P-type silicon top.

Symbol & Construction:

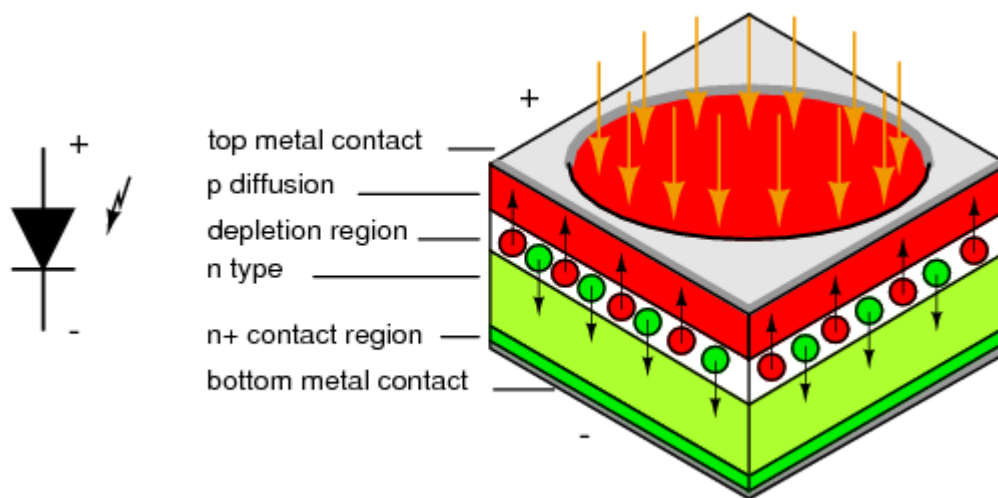

Fig 15 :Photodiode: Schematic symbol and cross section (below Photo diodes)

### Applications:

Photodiodes are used in [consumer electronics](#) devices such as [compact disc](#) players, [smoke detectors](#), and the receivers for infrared [remote control devices](#) used to control equipment from [televisions](#) to air conditioners. For many applications either photodiodes or photoconductors may be used. Either type of photosensor may be used for light measurement, as in [camera light meters](#), or to respond to light levels, as in switching on street lighting after dark.

Photodiodes may contain [optical filters](#), built-in lenses, and may have large or small surface areas. Photodiodes usually have a slower response time as its surface area increases. The common, traditional [solar cell](#) used to generate electric [solar power](#) is a large area photodiode.

### Infrared LED

*IR LED is used in this circuit to transmit infrared light.*

*An Infrared light-emitting diode (IR LED) is a type of electronic device that emits infrared light not visible to the naked eye.*

The wavelength and colour of the light produced depend on the material used in the diode. Infrared LEDs use material that produces light in the infrared part of the spectrum, that is, just below what the human eye can see. Different infrared LEDs may produce infrared light of differing wavelengths, just like different LEDs produce light of different colours.



Since the human eye cannot see the infrared radiations, it is not possible for a person to identify whether the IR LED is working or not, unlike a common LED. To overcome this problem, the camera on a cell phone can be used. The camera can show us the IR rays being emanated from the IR LED in a circuit.

Symbol of IR LED:

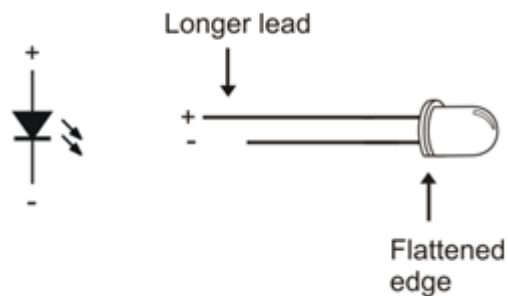

Infrared LEDs can be divided into the following three types: small power one (1mW-10mW), medium power LED (10mW-50mW) and large power LED (50mW-100mW and above). The modulated light can be generated by adding pulse voltage with specific frequency on the driving diode.

**Infrared emitting diode infrared light, the principle and characteristics are as follows :** the matrix of infrared light-emitting diode light . Infrared emission diode by the infrared radiation efficiency of the material ( commonly gallium arsenide GaAs) made of a PN junction , applied to the PN junction forward bias injection current excitation infrared light. Infrared diode current is too small.

Applications:

Infrared LED chips with different wavelengths can be applied in extensive devices, for example:

1. Free air transmission system
2. Optoelectronic switch
3. Floppy disk drive
4. Infrared applied system
5. Smoke detector
6. [video surveillance camera](#)
7. Infrared LED chip with wavelength of 940nm: suitable to be used in remote controller, such as remote controllers for household appliances.
8. 808nm: suitable to be used in medical treatment appliances, space optical communication, infrared illumination and the pumping sources of the solid-state lasers.
9. 830nm: suitable to be used in the automated card reader system in freeway.
10. 840nm: suitable to be used in colored zoom infrared waterproof video camera.
11. 850nm: suitable to be used in video cameras that are applied in digital photography, monitoring system, door phone, theft proof alarm and so on.
12. 870nm: suitable to be used in video cameras in marketplace and crossroad.

## Chapter review Questions:

- 1 Define Rectifier & state its use.
- 2 Explain P-type and N-type semiconductor junction .
- 3 Define PN junction Barrier voltage, depletion region, Junction Capacitance.
- 4 Draw Forward biased & reversed biased junction Diode
- 5 Draw symbol, circuit diagram for characteristics (Forward & reversed) Characteristics PN junction diode.
- 6 Define Forward voltage drop, Reversed saturation current, maximum forward current ,power dissipation Package view of diodes of different power ratings
- 7 Explain Construction (reference to doping level),Symbol ,circuit diagram for characteristics (forwarded & reversed) of Zener Diode
- 8 Explain Avalanche & Zener breakdown and its comparison.
- 9 Define Zener voltage, power dissipation, breaks over current, dynamic resistance & maximum reverse current.
- 10 Explain Construction ,Symbol ,circuit diagram for characteristics of Schottky diode
- 11 Explain Construction ,Symbol ,circuit diagram for characteristics of Tunnel diode
- 12 Define Optical Diodes
- 13 Explain Construction ,Symbol ,circuit diagram for characteristics of LED,
- 14 Explain IR LED & its working principle.
- 15 Explain Construction ,Symbol ,circuit diagram for characteristics of photodiode

## Chapter-3 Rectifiers & Filters.

**3.1 Rectifier: Definition-** A semiconductor device which converts of an alternating current ( AC ) into direct current ( DC ).

**Example : Semiconductor Diode.**

**Need of Rectifier:** To provide continuous voltage ( DC Voltage ) required to run almost all electronic devices & circuits.

### 3.1.1 Types of Rectifier : Half Wave Rectifier.

In this type the rectifier conducts current only during the + ve half cycles of the a.c. supply.

**Simple Circuit:**

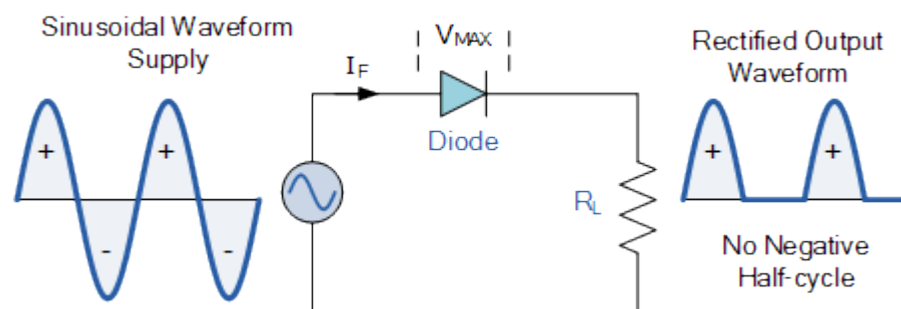

Here - ve half cycles are suppressed i.e. during -ve half cycle no current passes through the diode hence no voltage appears across the load.

Max. rectifier Efficiency= Max. d.c.output power/ a.c. input power =40.6%

### Schematic Diagram:

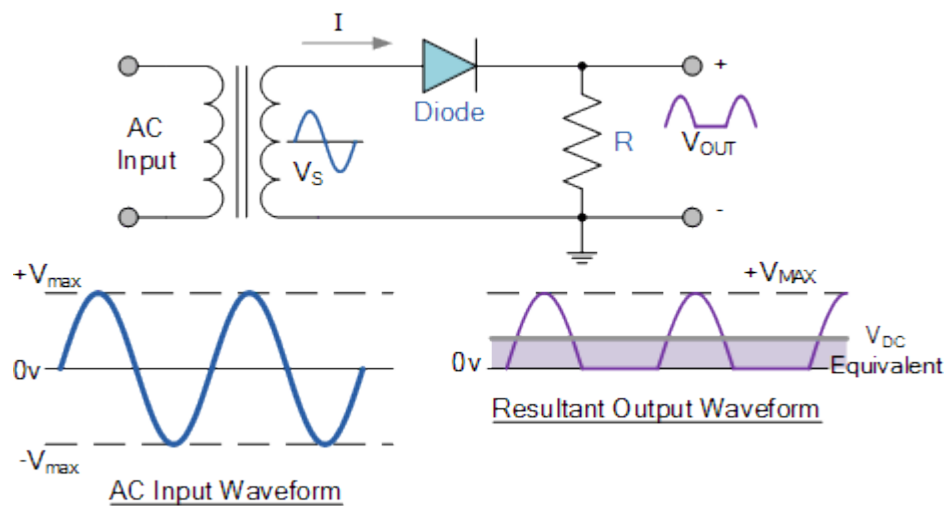

### Full Wave Rectifier:

In this type, the rectifier utilizes both half cycles of a.c. input voltage to produce the d.c. output.

#### Full Wave Rectifier(Centre Tapped Type)

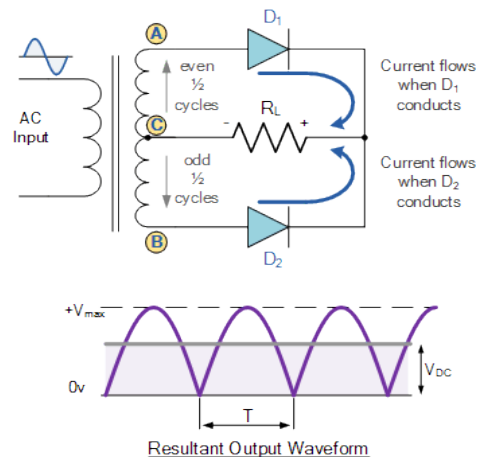

During the positive half cycle of the supply, diode  $D_1$  conducts, while diode  $D_2$  is reverse biased and the current flows through the load as shown.

Similarly, during the negative half cycle of the supply, diode  $D_2$  conducts, while diode  $D_1$  is reverse biased and the current flows through the load as shown.

#### Full Wave Rectifier( Bridge Type) : The Diode Bridge Rectifier

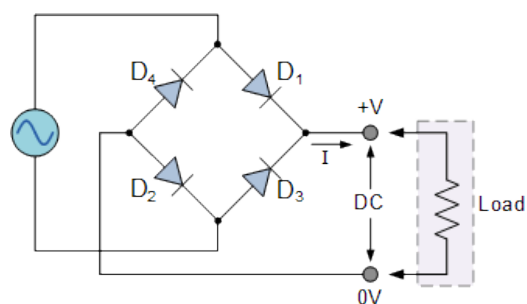

During the positive half cycle of the supply, diodes **D1** and **D2** conduct in series while diodes **D3** and **D4** are reverse biased and the current flows through the load as shown below.

### The Positive Half-cycle

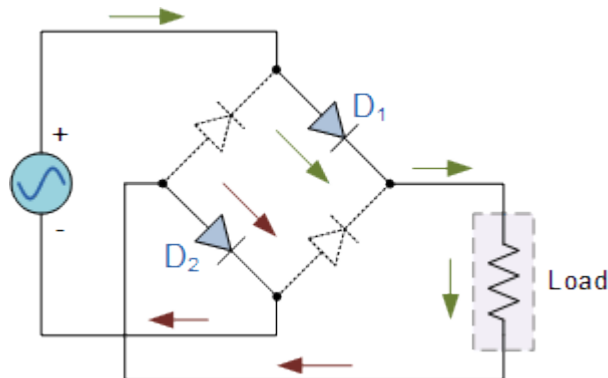

During the negative half cycle of the supply, diodes **D3** and **D4** conduct in series, but diodes **D1** and **D2** switch "OFF" as they are now reverse biased. The current flowing through the load is the same direction as before.

### The Negative Half-cycle

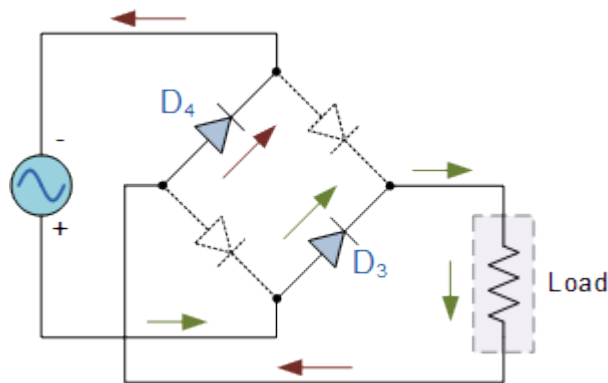

Max. rectifier Efficiency = Max. d.c.output power / a.c. input power =  $\eta = 81.2\%$

**3.1.2 Ripple:** Ripple is the output of a rectifier that contains both dc & ac component.

Ripple Factor : The ratio of r.m.s value of ac component to the dc component in the rectifier output is known as ripple factor.

Ripple Factor = r.m.s value of ac component / value of dc component.

For Half wave rectification ripple factor = 1.21

For Full wave rectification ripple factor = .48

PIV (Peak Inverse Voltage) : It is the maximum reverse voltage that a diode can withstand without destroying the junction.

TUF(Transformer Utility Factor): Defined as the ratio of power delivered to the load to the ac rating of the transformer secondary.

TUF = dc power delivered to the load/ac rating of transformer secondary

$$= P_{dc} / P_{ac.rated}$$

$$= P_{dc} / P_{in.rated}$$

**Rectifier Efficiency:** The ration of dc power output to the applied input ac power is known as rectifier efficiency.

$$\text{Rectifier Efficiency} = \text{dc power output} / \text{input ac power}$$

### 3.1.3 Comparison of Three types of Rectifier.

Sl . No.	Particulars	Half wave	Centre-Tap FWR	Bridge FWR
1.	No. of Diodes	1	2	4
2.	Max. Efficiency	40.6%	81.2%	81.2%
3.	Ripple Factor	1.21	0.48	0.48
4.	Output Frequency	50Hz	100Hz	100Hz
5.	PIV(Peak Inverse Voltage)	V <sub>m</sub>	2V <sub>m</sub>	V <sub>m</sub>

### 3.2 FILTERS:

Definition: A filter circuit is a device which removes the ac component (ripple) of rectifier output but allows the dc component to reach the load.

Need of Filter: To provide smooth DC output to the load.

Types of Filter:

- i) Shunt Capacitor: It is also called Capacitor Filter. It offers low reactance to ac & a very high reactance to the dc component.

The capacitive reactance is  $X_C = 1/2\pi fc$  ,for d.c ,  $f=0$  Then,  $X_C = \infty$

Hence a capacitor does not allow the d.c to pass through it.

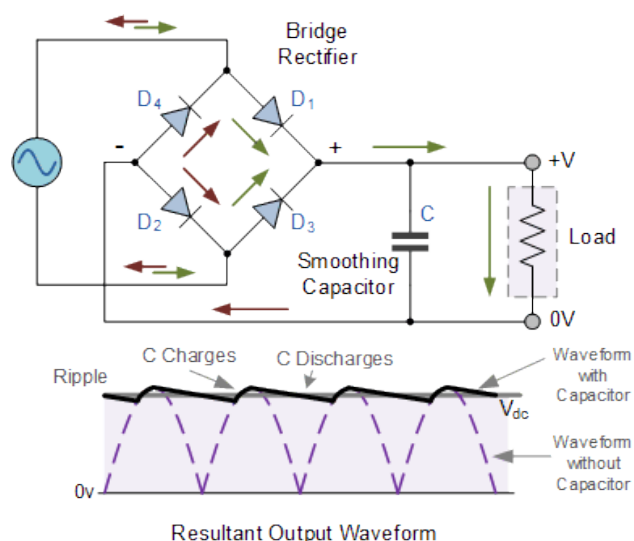

ii) Choke input filter : In this filter one inductor & one capacitor is used.

The inductive reactance is  $X_L = 2\pi fL$ , for d.c,  $f(\text{frequency}) = 0$ . Then,  $X_L = 0$ , Hence inductor allows the d.c to pass through it.

It offers high reactance to the ac component but offers almost zero reactance to the dc component. That means it allows only dc component to flow through it.

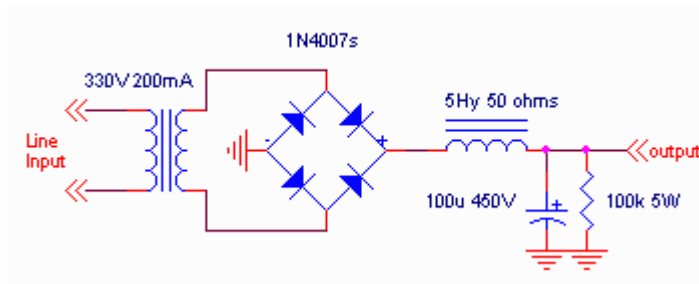

iii) **Capacitor input filter:** It is also called  $\pi$ -Filter.

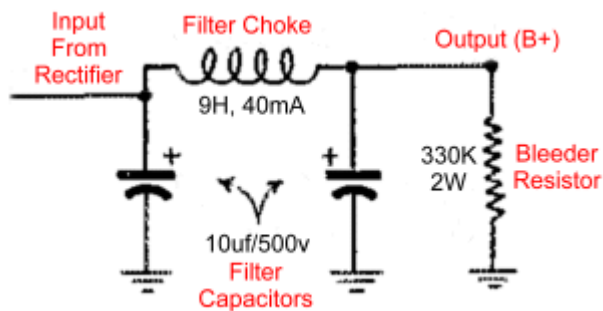

In this filter one inductor & two capacitors are used.

Here pulsating output from rectifier is applied across 1<sup>st</sup> capacitor which offers zero reactance to a.c & infinite reactance to d.c. Hence d.c component continues to reach across L(Choke Filter).

The filter choke then allows the d.c component easily by blocking a.c component if any.

Finally the 2<sup>nd</sup> capacitor across load bypasses the a.c component if any which the choke(L) failed to block by making d.c component to reach across load.

### Chapter Review Questions:

1. Define rectifier.
2. Draw the circuit of centre tap FWR & Bridge FWR.
3. State PIV of a diode.
4. Define TUF.
5. State the full wave rectifier efficiency.
6. Compare HWR & FWR.
7. Need of filter in power supply.
8. State different types of filters .
9. Define ripple & ripple factor.
10. Define rectifier efficiency.

## Chapter-4 Transistors

4.1 *Definition: A semiconductor device which transfers a signal from a low resistance to high resistance.*

Construction: A transistor consists of two pn junctions formed by sandwiching either p-type or n-type semiconductor between a pair of opposite types.

Accordingly there are two types of transistors namely ;

- i) p-n-p transistor
- ii) n-p-n transistor

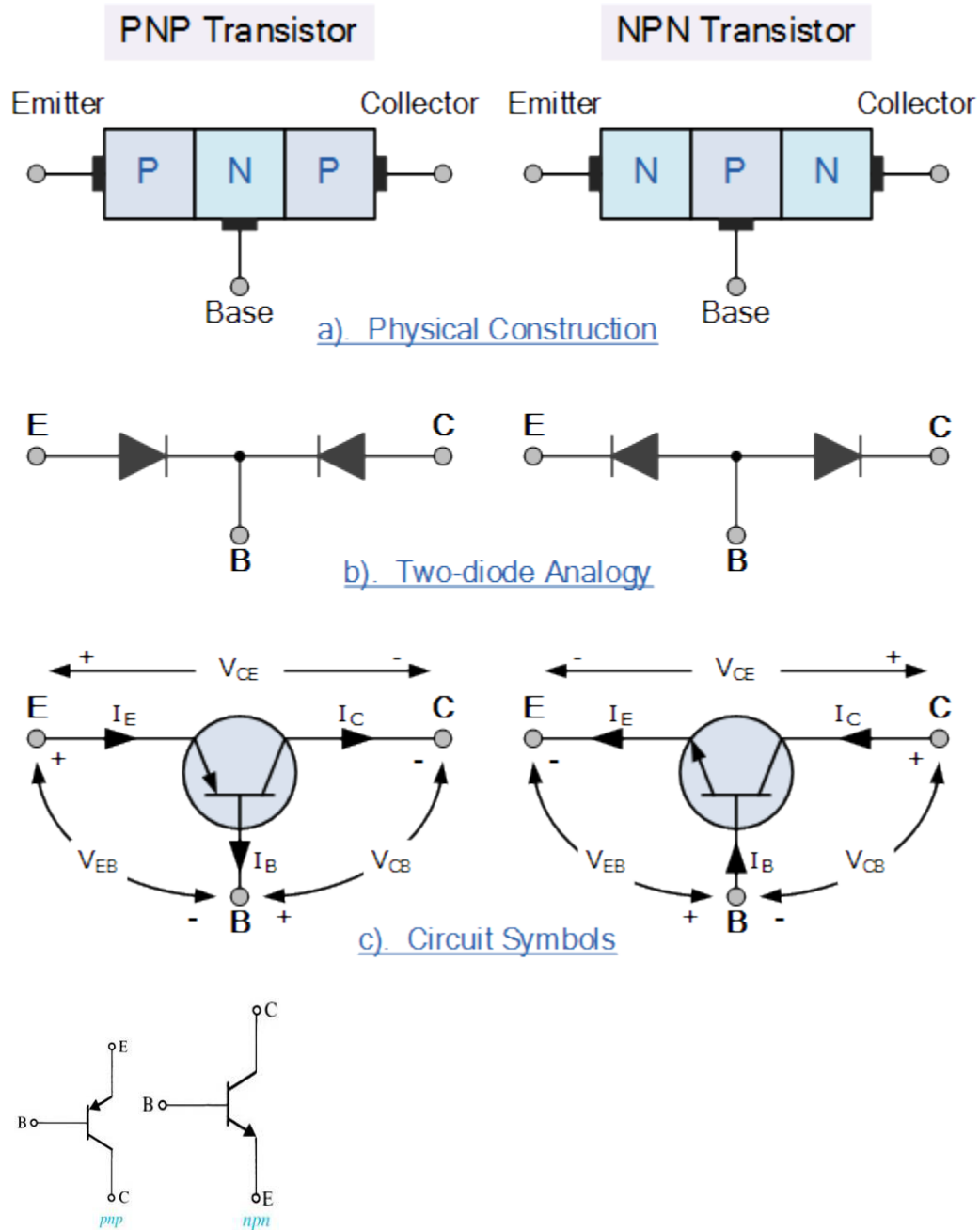

The direction of emitter arrow indicates direction of current flow.

Advantages: Small size ,Light weight ,Low supply voltage, No heating, High voltage gain ,Mechanically strong.

Bipolar Junction Transistor (BJT): A BJT consists of two pn junctions formed by sandwiching either p-type or n-type semiconductor between a pair of opposite types.

#### 4.1.1 Types of Transistor (BJT) Basic concept:

##### NPN transistor.

It has three sections of doped semiconductors.

- Emitter: The section on one side that supplies carriers(Electrons/Holes) is called Emitter. The emitter is always forward biased w.r.t. base so that it can supply large no of majority carriers(Electrons)
- Base: The middle section which forms two pn junctions between emitter & collector is called the Base.
- Collector: The section on one side that collects carriers(Electrons/Holes) is called Collector . The collector is always forward reverse biased w.r.t. base. Its function is to removes charges from its junction with the base.

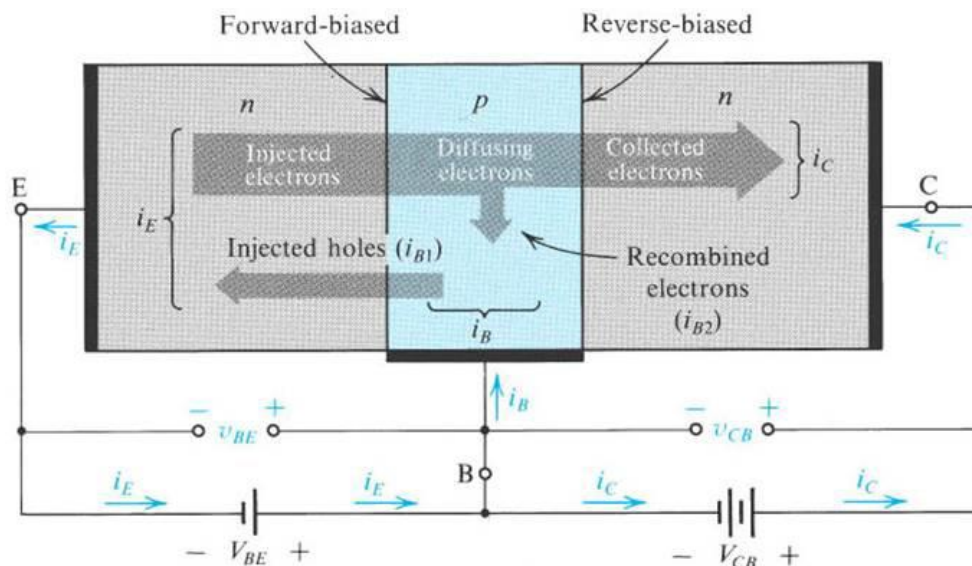
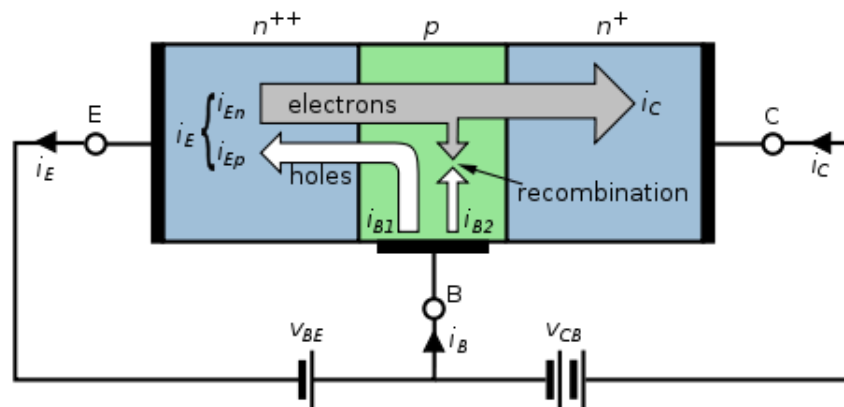



- Conventional Current Flow in npn: The base emitter junction is forward biased . allowing low resistance in emitter (input) side & base-collector junction is reverse biased & provides high resistance in collector(Output) side .
- Accordingly the current flows from emitter towards base & collector

Therefore , Using Kirchoff's Current Law:

$$I_E = I_B + I_C$$

$$\text{Emitter Current} = \text{Base Current} + \text{Collector Current}$$

PNP transistor: Similarly the in pnp , the current conduction is due to majority carriers i.e. Holes as shown below.

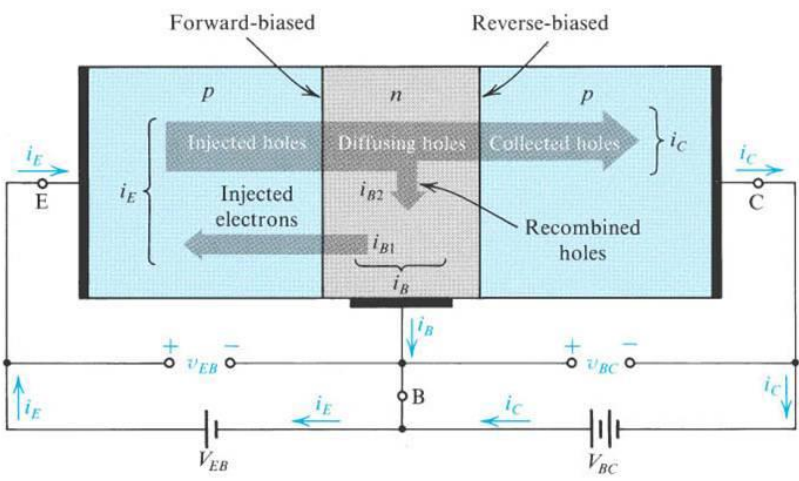

Fig 16 :Relation between different currents in transistor (  $I_E$  ,  $I_B$  ,  $I_C$  )

Using Kirchoff's Current Law:

$$I_E = I_B + I_C$$

$$\text{Emitter Current} = \text{Base Current} + \text{Collector Current}$$

#### 4.1.2 Transistor Configurations:CB ,CE& CC

As the **Bipolar Transistor** is a three terminal device, there are basically three possible ways to connect it within an electronic circuit with one terminal being common to both the input and output. Each method of connection responding differently to its input signal within a circuit as the static characteristics of the transistor vary with each circuit arrangement.

- **Common Base Configuration** - has Voltage Gain but no Current Gain.
- **Common Emitter Configuration** - has both Current and Voltage Gain.

- **Common Collector Configuration** - has Current Gain but no Voltage Gain.

The Common Base (CB) Configuration:

As its name suggests, in the Common Base or grounded base configuration, the **BASE** connection is common to both the input signal AND the output signal with the input signal being applied between the base and the emitter terminals. The corresponding output signal is taken from between the base and the collector terminals as shown with the base terminal grounded or connected to a fixed reference voltage point.

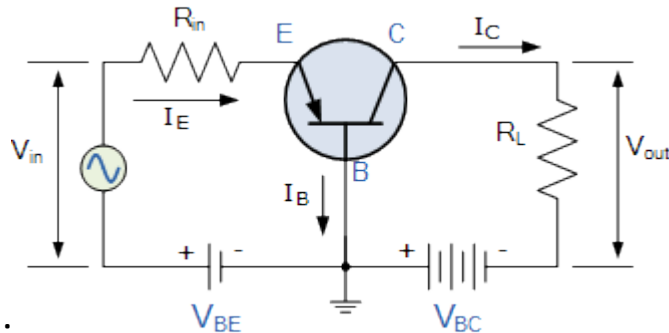

**Input Output Characteristics :**

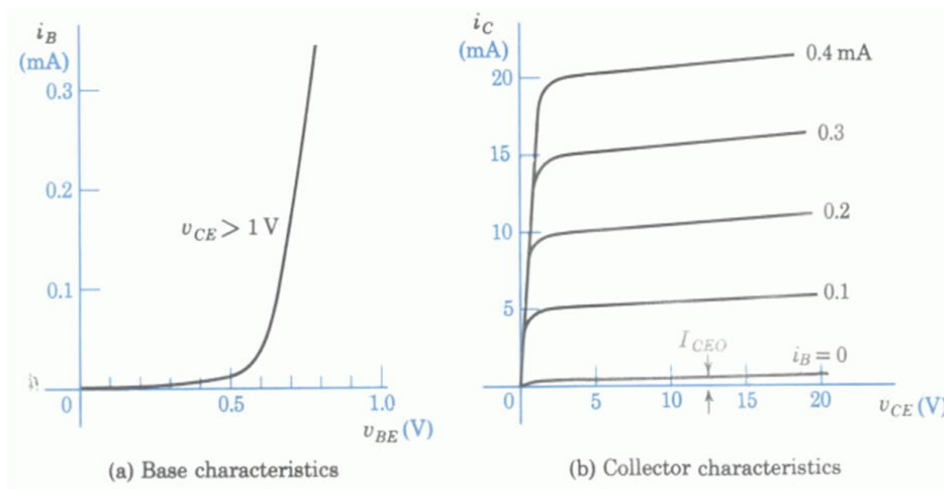

The Common Emitter (CE) Configuration:

In the Common Emitter or grounded emitter configuration, the input signal is applied between the base, while the output is taken from between the collector and the emitter as shown. This type of configuration is the most commonly used circuit for transistor based amplifiers and which represents the "normal" method of bipolar transistor connection.

**Circuit diagram to find the characteristics :**

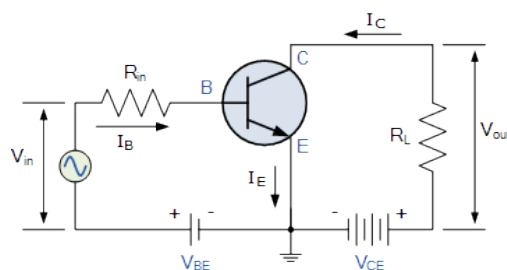

## Input Characteristics:

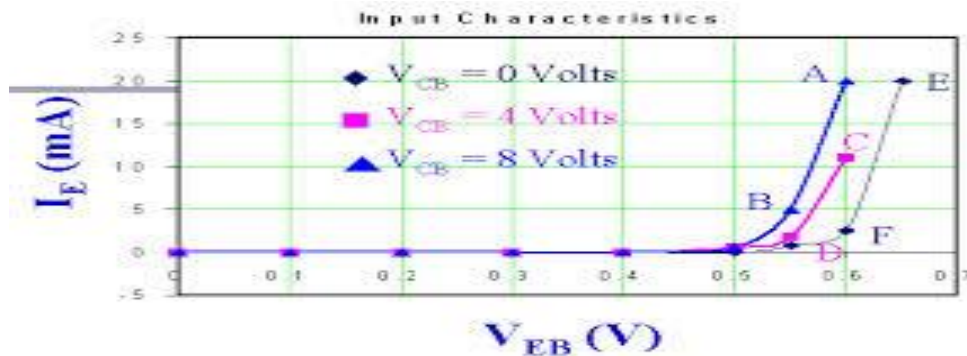

## Output Characteristics:

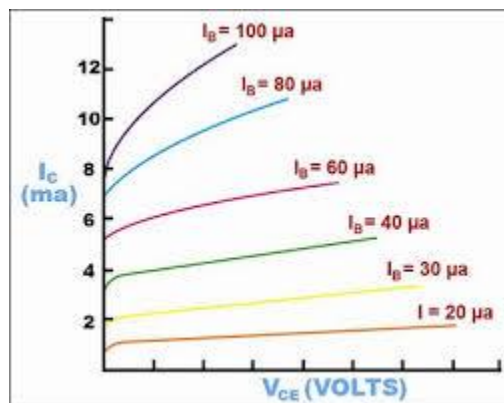

The Common Collector (CC) Configuration:

In the Common Collector or grounded collector configuration, the collector is now common through the supply. The input signal is connected directly to the base, while the output is taken from the emitter load as shown. This type of configuration is commonly known as a

Voltage Follower or Emitter Follower circuit: The emitter follower is a current amplifier that has no voltage gain.

Its important characteristics are:

- i. No voltage gain.
- ii. It has high input impedance & low out put impedance.
- iii. Relatively high current & power gain.
- iv. Input & output ac voltages are in phase.

Thus it is an ideal circuit for impedance matching & DC load line analysis.

### Circuit diagram of Emitter Follower :

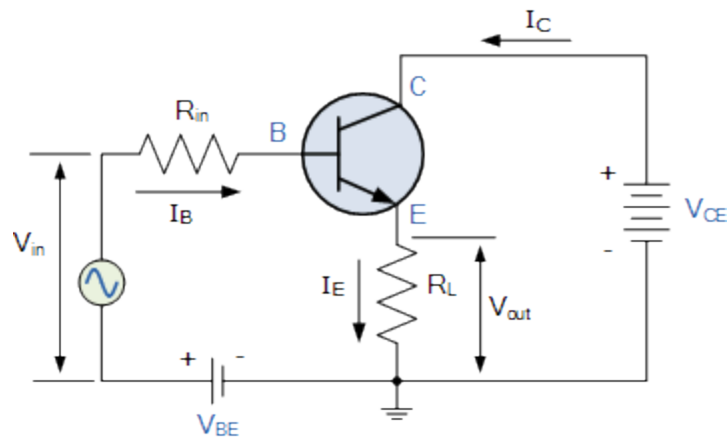

Working Principle: As the collector is at ac ground , the circuit is known as CC amplifier.

- i) There is no collector load(  $R_C$  ) and emitter bypass capacitor (  $C_E$  )
- ii) The emitter resistor (  $R_E=R_L$  ) itself acts as the load.
- iii) The biasing is provided by input resistor (  $R_{in}$  )

Characteristics:

- i) When transistor is saturated ,  $V_{CE}=0$

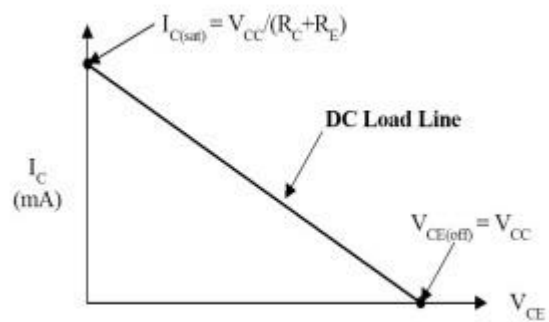

- ii) When transistor is off  $I_{C(Sat)}=V_{CC}/$

**Input Output Characteristics: Same as that of Common Base configuration.**

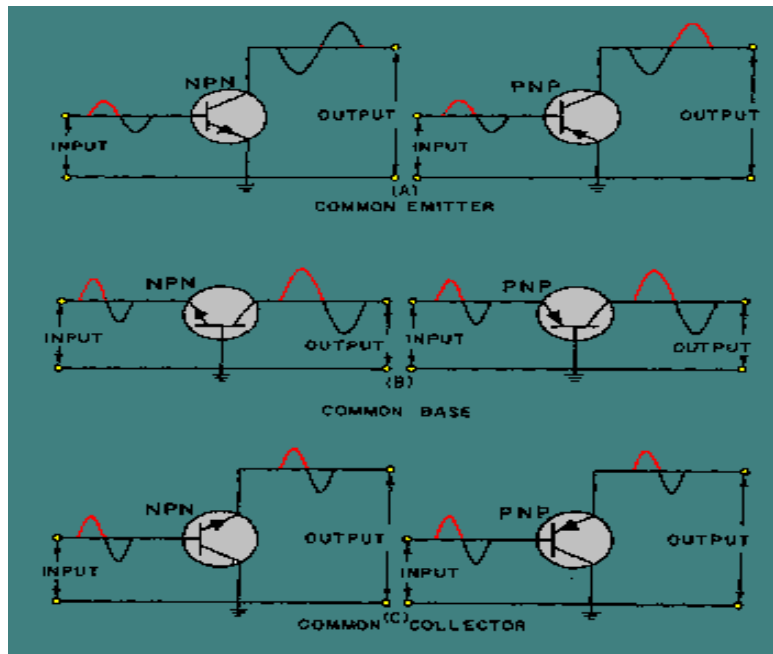

#### 4.1.3 Transistor Parameters:

Input Resistance :It is the ratio of change input voltage to the change in input current.

Output Resistance : It is the ratio of change output voltage to the change in output current.

Transistor Parameters	CB	CE	CC
I/P Resistance	Low	Low	Very High
O/P Resistance	Very High	High	Low
Application	High frequency	Audio frequency	Impedance Matching

Relation between  $\alpha$  ,  $\beta$  &  $\gamma$  :

Current Amplification Factor in common Base( $\beta$ ):

Defined as the ratio of change in collector current to the change in base current is known as current amplification factor in CB configuration.

$$\beta = \frac{\Delta I_C}{\Delta I_B}$$

Mathematically,

Current Amplification Factor in common Emitter( $\alpha$  ):

Defined as the ratio of change in collector current to the change in base current is known as current amplification factor in CE configuration.

$$\alpha = \frac{\Delta I_C}{\Delta I_E}$$

Mathematically ,

Current Amplification Factor in common Collector ( $\gamma$ ):

Defined as the ratio of change in emitter current to the change in base current is known as current amplification factor in CC configuration.

Mathematically , 
$$\gamma = \frac{\Delta I_E}{\Delta I_B}$$

Relation between  $\alpha$  ,  $\beta$  &  $\gamma$  : 
$$\alpha = \frac{\beta}{\beta + 1} \quad \beta = \frac{\alpha}{1 - \alpha} \quad \gamma = \beta + 1$$

$$\beta = \frac{\Delta I_C}{\Delta I_B} , \quad \alpha = \frac{\Delta I_C}{\Delta I_E} , \quad \gamma = \frac{\Delta I_E}{\Delta I_B}$$

$$\gamma = \frac{\Delta I_E}{\Delta I_B} , \quad \alpha = \frac{\Delta I_C}{\Delta I_E} \quad \alpha = \frac{\beta}{\beta + 1}$$

$$\alpha = \frac{\beta}{\beta + 1} \quad \beta = \frac{\alpha}{1 - \alpha} \quad \gamma = \beta + 1$$

For Example: We know  $I_E = I_B + I_C$

If  $I_B = 5\%$  &  $I_C = 95\%$  , Then  $I_E = 100\%$

Transistor Specification :

$V_{CEsat}$ : Collector emitter saturation voltage

$I_{CMax}$ : Maximum Collector Current.

$V_{CEO}$  : Collector emitter voltage with base open circuit

$I_{CEO}$  : Collector emitter cut-off current .

$\alpha$ = Current Amplification Factor in common Emitter\_\_.

$\beta$ =Current Amplification Factor in common Base\_\_.

$V_{CE}$  breakdown: Collector to emitter breakdown voltage .

Power Dissipation: It is due to large currents for which the transistor heats up (thermal effect) during its operation.

Remedy: By using Heat Sink ( made up of metal case) the heat can be dissipated &the device can be expected to operate without self-damage.

#### 4.1.5 Construction , Working Principle , Characteristics of Photo Transistor:

Photo Transistor :

A phototransistor is a light-sensitive transistor. A **bipolar transistor** encased in a transparent case so that **light** can reach the base-collector junction.

Phototransistor symbol

The phototransistor symbol for use in electronic circuit diagrams is very straightforward. It is formed from the basic transistor symbol with arrows point in to it to indicate that it is light sensitive.

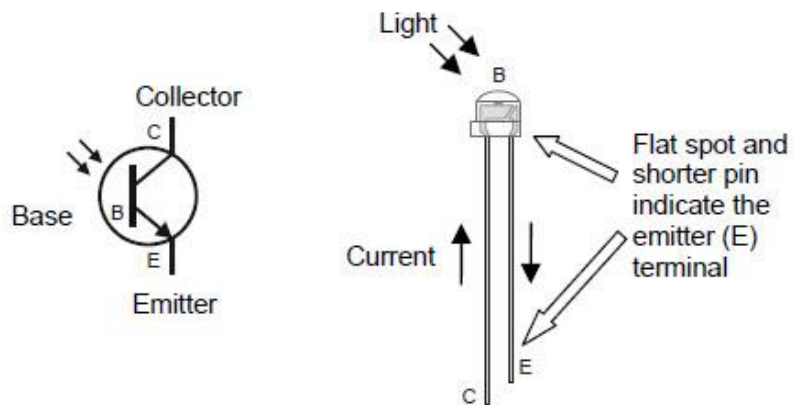

Working Principle: The electrons that are generated by photons in the base-collector junction are injected into the base, and this photodiode current is amplified by the transistor's current gain  $\beta$ . If the emitter is left unconnected, the phototransistor becomes a photodiode.

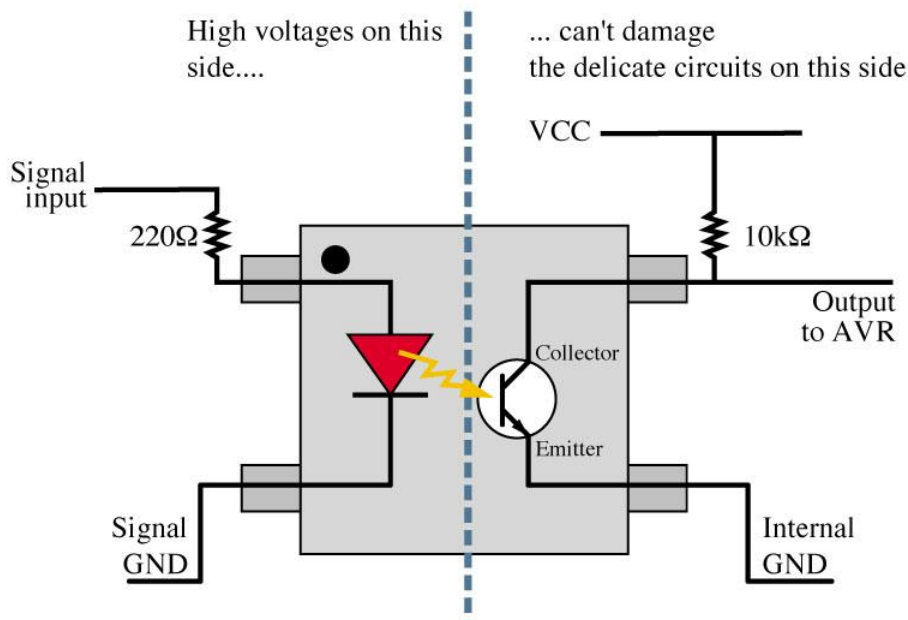
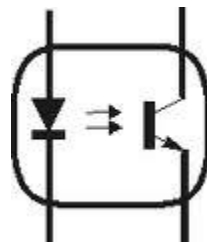

### Phototransistor circuit:

The phototransistor circuit configuration has effectively the same topology as the normal common emitter transistor circuit - the emitter is taken to ground via a load resistor, and the output for the circuit being taken from the emitter connection of the device.

The circuit generates an output that moves from the low state to a high state when light is detected.

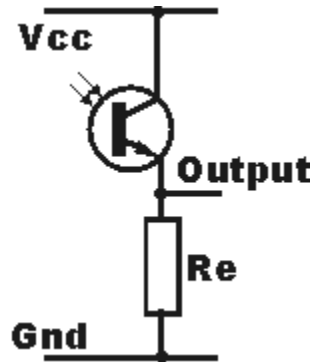

Common collector / emitter follower phototransistor circuit

### Phototransistor circuit operation:

The phototransistor circuits can be used on one of two basic modes of operation.

They are called active or linear mode and a switch mode.

Active Mode of Operation: In this mode the phototransistor gives linear output which is proportional to the light intensity (Stimulus) that falls on its base. Here transistor is ON state.

Switch mode of Operation : In this mode no light falls on the base of transistor therefore no current flows, and it can be said to be in the "OFF" state.

Use: This type of phototransistor mode is useful for detecting objects, sending data or reading encoders, etc. The phototransistor can be used in a variety of circuits and in a number of ways dependent upon the application. Being a low cost device the phototransistor is widely used in electronic circuits.

**Opto-Coupler** An optocoupler is a device that uses light (LED) to couple a signal from its input to its output ( Photodiode). The opto-coupler or opt isolator is essentially a device that uses a short optical path to couple an electrical signal from one area to another. Typically the opto coupler is **housed within a single small package, often around the size of a small integrated circuit, although sizes vary according to the application and the specification.**

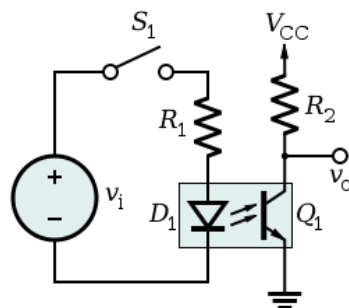

Circuit of Photo transistor opto coupler :



Application: Opto couplers / opto isolators are used for a variety of applications from providing voltage isolation between two circuits to coupling data circuits - one application for opt coupler technology is for use within optical encoders, where the opto-coupler provides a means of detecting visible edge transitions on an encoder wheel to detect position, etc.

## 4.2 Unipolar Transistor (JFET)

Junction Field Effect Transistor: A JFET is a three terminal semiconductor device in which current conduction is by one type of carrier i.e., electrons or holes.

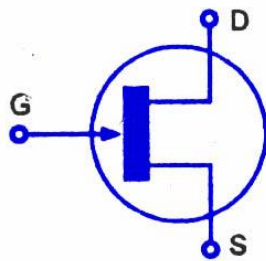

*N-Channel JFET*

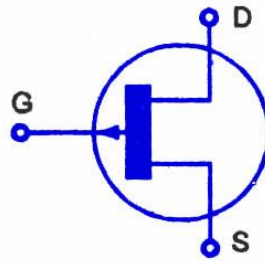

*P-Channel JFET*

Symbol: *Schematic Symbols For JFETs*

### Construction:

A JFET consists of a p-type or n-type silicon bar containing two pn junctions at the sides as in figure below.

JFET has three terminals viz., Gate (G) , Source(S) and Drain(D)

The bar forms the conducting channel for the charge carriers.

N-channel JFET: If the bar is of n-type , it is called n-channel JFET as shown below.

P-channel JFET: If the bar is of p-type , it is called p-channel JFET as shown below.

### **Construction :**

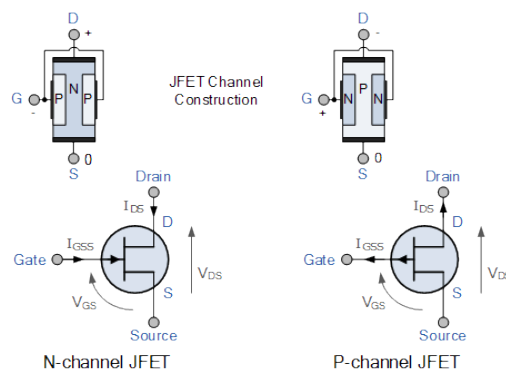

**Construction :**

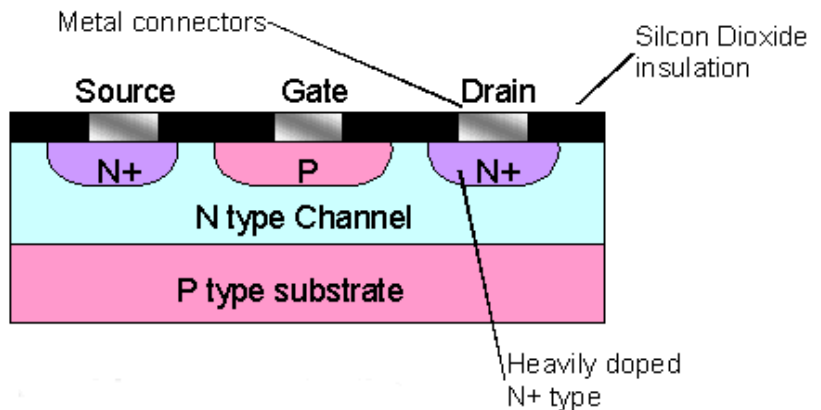
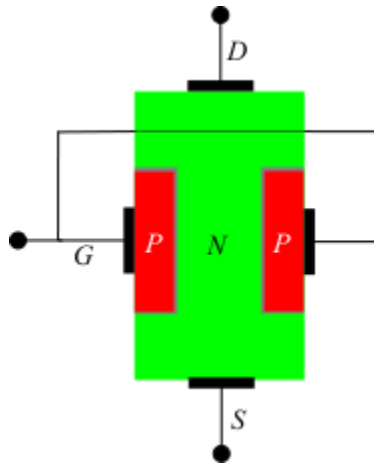
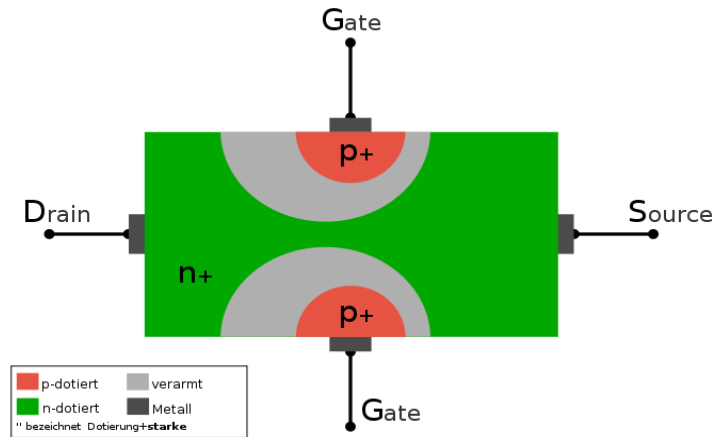

Working Principle :

The JFET operates on the principle that channel width and hence resistance of the conducting channel can be varied by changing the reverse voltage between gate to source ( $V_{GS}$ ).

- i) The input circuit ( i.e. gate to source ) of a JFET is always reverse biased. This means that the device has high input impedance.

- ii) The drain is so biased w.r.t. source that drain current  $I_D$  flows from the source to drain.
- iii) In all JFET s source current  $I_S$  is equal to drain current  $I_D$ . e.  $I_S = I_D$

Applications :

- i) Impedance Matching (High I/P & Low O/P for low noise application)
- ii) Phase shift Oscillator (To minimise Loading Effect)
- iii) As RF Amplifier( Reducing noise level & will respond to low signal at the antenna)

#### 4.2 Biasing of BJT :

The proper flow of zero signal collector current and maintenance of proper collector –emitter voltage during passage of signal is known as transistor biasing.

That means to keep the base-emitter junction properly forward biased & collector–base junction properly reverse bias during the application of signal.

##### 4.3.1 Introduction:

Need of Biasing: Transistor biasing is required for faithful amplification. That means the process of raising the strength of a weak signal without any change in its general shape is known as faithful amplification.

To ensure this the following basic conditions must be satisfied:

- i) Proper flow of zero signal collector current.
- ii) Minimum proper base-emitter voltage ( $V_{BE}$ ) at any instant.
- iii) Minimum proper collector-emitter voltage ( $V_{CE}$ ) at any instant.

Transistor biasing: The proper flow of zero signal collector current and the maintenance of proper collector –emitter voltage during the passage of signal is known as transistor biasing.

The basic purpose of transistor biasing to keep the base-emitter junction properly forward biased & collector–base junction properly reverse biased during the application of signal.

Types of Biasing Circuits : Considering simplicity & cost , the most common methods of transistor biasing from one source supply (i. e.  $V_{CC}$  ) are:

1. i) Base bias method.
2. ii) Voltage divider bias .
3. iii) Biasing with collector –feed back resistor
4. Emitter bias method.

##### **Base Bias Circuit:**

In this method a high resistance  $R_B$  is connected between the base & negative end of supply for npn transistor as shown in fig below.

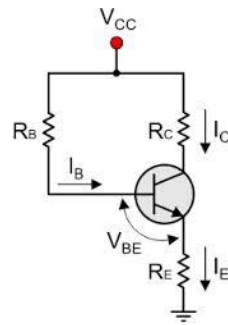

Circuit Operation of Base Bias Circuit : The required zero signal base current is provided by  $V_{CC}$  and it flows through  $R_B$ .

$$\text{i.e. } I_C = \beta I_B \quad \text{and} \quad V_{CC} = I_B R_B + V_{BE}$$

$$R_B = \frac{V_{CC}}{I_B} \quad , \quad \text{as } V_{BE} \text{ is quite small as compared to } V_{CC}$$

It is because base is +ve w.r.t emitter so that base emitter junction is forward biased .

Concept of DC Load Line : It is the line on the output characteristics of a transistor circuit which gives the values of  $I_C$  and  $V_{CE}$  corresponding to zero signal or dc conditions

Saturation : It is the maximum value of for a particular load in a transistor collector current. In this state transistor behaves like a virtual short (collector - emitter shorted) ) i. e.,  $I_C = \text{Maximum} \quad \& \quad V_{CE} = 0$

Cut-off : When the input base voltage is zero or negative , the transistor is said to be Cut-off condition. In this state transistor behaves like an open circuit (collector - emitter open) i. e.,  $I_C = 0 \quad \& \quad V_{CE} = V_{CC}$

### DC load line:

DC load line can be constructed by locating the two end points  $I_{C(\text{Sat})}$  and  $V_{CE(\text{off})}$ .

- i) When transistor is saturated ,  $V_{CE} = 0$

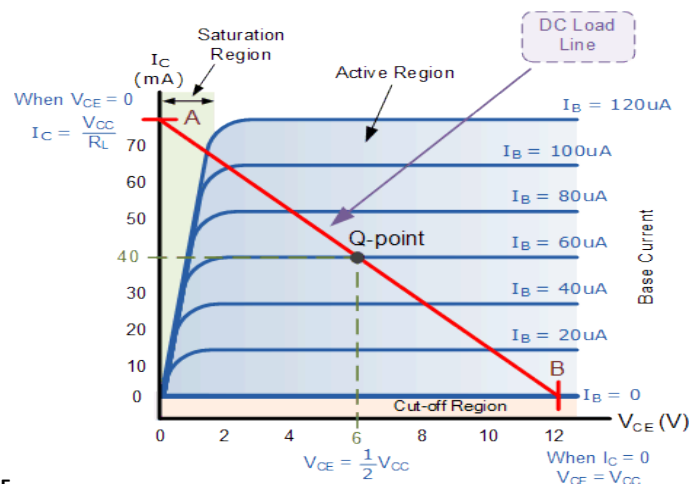

- ii) When transistor is off  $I_{C(\text{Sat})} = \frac{V_{CC}}{R_E}$

## Selection operating point (Q-point)

Q point means the quiescent point its depend upon the collector current when collector current is stable then it is stable its can be find from load line diagram where AC load line and DC load line intersect its called Q point.

Three operating points of transistor operating in common emitter amplifier.

1. Near cut off
2. Near saturation
3. In the middle of active region

If the operating point is selected near the cutoff region, the output is clipped in negative half cycle as shown in fig. A.

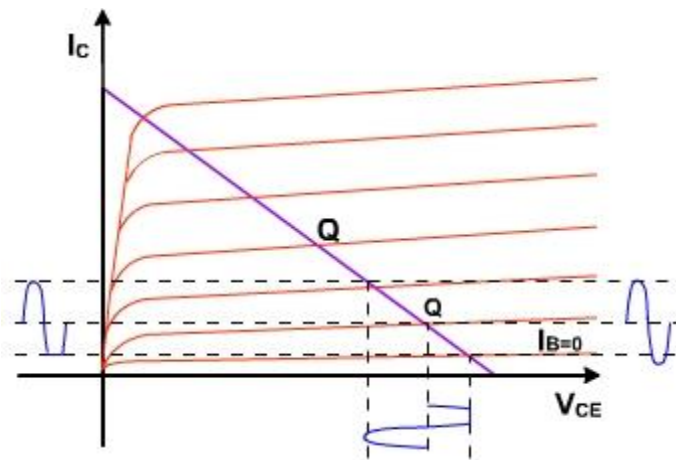

Fig. A

If the operating point is selected near saturation region, then the output is clipped in positive cycle as shown in [fig. B](#).

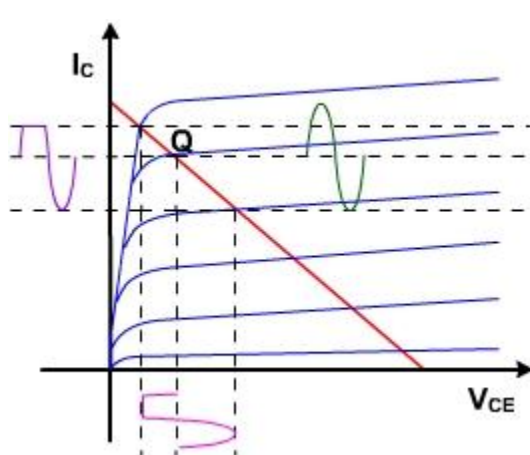

Fig. B

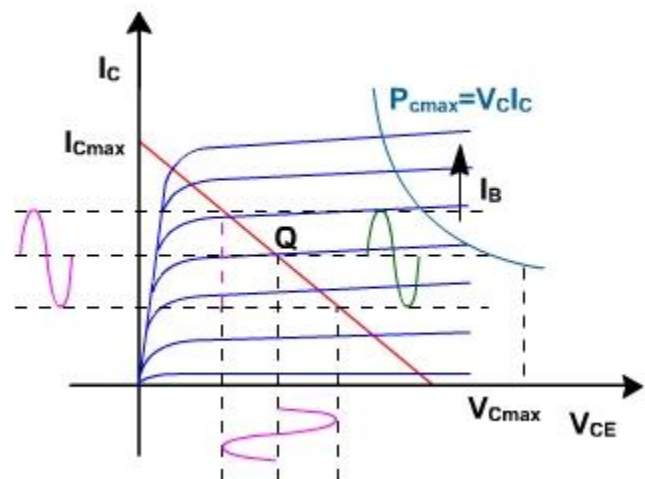

Fig. C

If the operating point is selected in the middle of active region, then there is no clipping and the output follows input faithfully as shown in [fig. C](#). If input is large then clipping at both sides will take place. The first circuit for biasing the transistor is CE configuration is fixed bias.

### **Need of Stabilisation :**

The process of making operating point independent of temperature changes or variations in transistor parameters is known as **stabilisation**.

Once stabilisation is done, the zero signal  $I_C$  and  $V_{CE}$  become independent of temperature variations or replacement of transistor *i.e.* the operating point is fixed.

A good biasing circuit always ensures the better stabilization of operating point.

**Need for stabilisation.** Stabilisation of the operating point is necessary due to the following reasons :

- (i) Temperature dependence of  $I_C$
- (ii) Individual variations
- (iii) Thermal runaway

### **Chapter Review Questions:**

1. What is a transistor ?
2. Define  $\alpha$  .
3. State relation between  $I_E$  ,  $I_B$  &  $I_C$  .
4. Draw the transistor symbols.
5. State different types of transistor configurations.
6. Draw the input output characteristics of common emitter configuration.
7. Define input & output resistance of transistor in common mode.
8. State relation between  $\alpha$  &  $\beta$  and  $\beta$  &  $\gamma$ .
9. State working principle of phototransistor.
10. Draw the symbol of n-channel & p-channel JFET . State the working principle & application of JFET.
11. State the need of biasing & name different types of biasing.
12. Draw the circuit of base bias method of biasing.
13. State saturation & cut-off of transistor.
14. What is Q -point ? State need of stabilization of Q-point .
15. State power dissipation of transistor.

## **Chapter-5 Regulated Power Supply.**

**5.1 Regulator:** A device which maintains the output voltage of an ordinary power supply constant.

Example: Zener diode is used as basic voltage regulator.

### **5.1.1 Need of Regulator: To ensure constant output voltage**

- i) In spite of load variations. (changes in load Current)
- ii) Changes in input a.c voltage .

**Voltage Regulation :** The variation of output voltage w.r.t the amount of load current drawn from the power supply is known as voltage regulation.

**Voltage Regulation Factor:** (Expressed as the % of voltage regulation)

$$\% \text{ Voltage Regulation} = (V_{NL} - V_{FL}) / V_{FL} \times 100$$

$V_{NL}$  = DC output voltage at no load.

$V_{FL}$  = DC output voltage at full load.

### 5.1.2 Concept of Load Regulation & Line Regulation:

**Load Regulation:** (Also called Voltage regulation) The load regulation indicates the change in output voltage due to change in load current .

**Line Regulation :** The line regulation of a voltage regulator indicates the change in output voltage that will occur per unit change in the input voltage.

### 5.1.3 Basic Zener Diode as a Voltage Regulator.

A zener diode can be used as a voltage regulator to provide a constant voltage from a source whose voltage may vary over sufficient range.

The zener diode of zener voltage  $V_Z$  is reversly connected across the load  $R_L$  across which constant output is desired . The series resistance  $R$  absorbs the output voltage fluctuations so as to maintain constant voltage across the load.

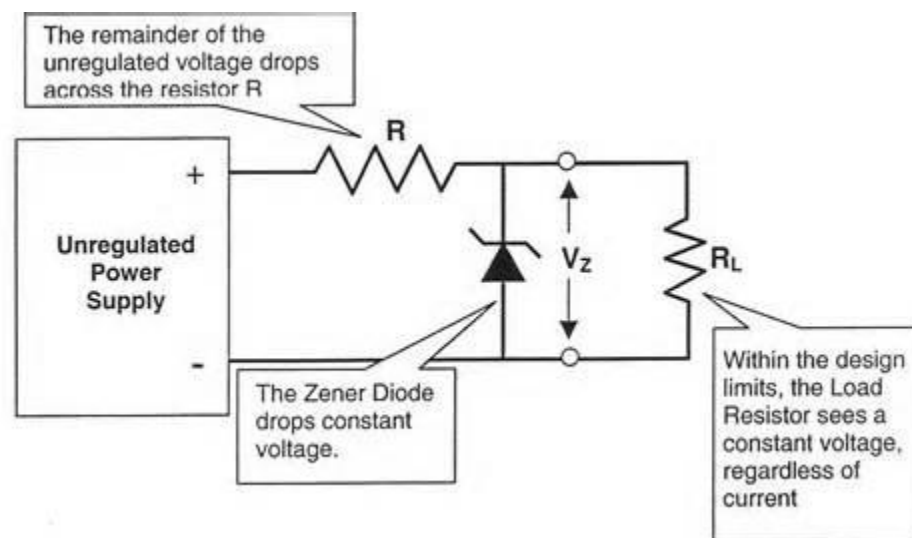

## 5.2 Line Regulators: As discussed above.

### 5.2.1 Basic Block Diagram of DC Regulated Power Supply.

**DC Regulated Power Supply:** A DC power supply which maintains the output voltage constant irrespective of a.c mains fluctuations Or load variations is known as regulated DC Power Supply.

Basic Block Diagram :

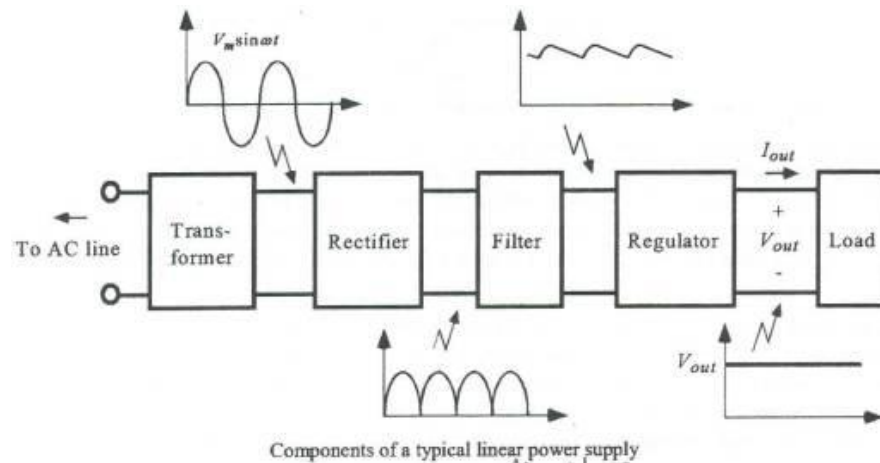

Working Principle: The output of power supply ( $V_{in}$ ) is fed to the voltage regulator which produces the final output ( $V_{load}$ ). The output voltage ( $V_{load}$ ) remains constant whether the load current changes or there are fluctuations in the AC input.

### 5.3 IC s Voltage Regulator : 78XX , 79XXv(Fixed) & LM- 317(As Variable)

78XX Series of IC Regulators: This series of IC regulator provides fixed positive voltage.

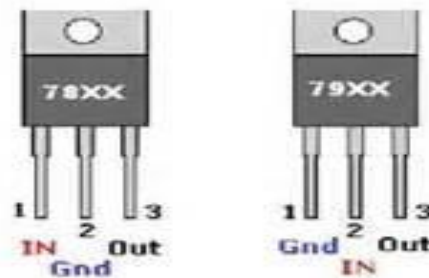

Pin Description:

Pin No	Function	Name
1	Input voltage (5V-18V)	Input
2	Ground (0V)	Ground
3	Regulated output; 5V (4.8V-5.2V)	



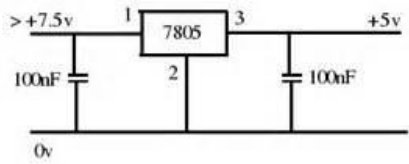

Example: 78XX Series.

IC Number	Output Voltage.
7805	+5.0 V
7808	+8.0 V
7812	+12.0 V
7818	+18.0 V
7824	+24.0 V

79XX Series of IC Regulators: This series of IC regulator provides fixed negative voltage.

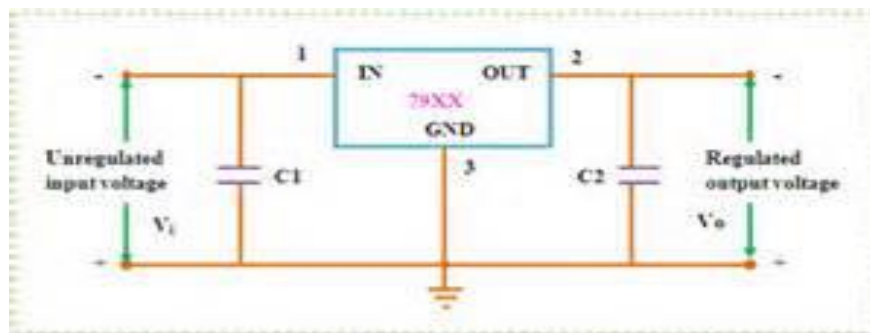

Pin Description:

Pin No	Function	Name
1	Ground (0V)	Ground
2	Input voltage (5V-18V)	Input
3	Regulated output; 5V (4.8V-5.2V)	

Example: 79XX Series.

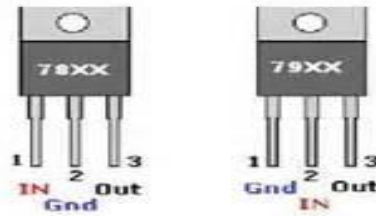

IC Number	Output Voltage.
7905	-5.0 V
7908	-8.0 V
7912	-12.0 V
7918	-18.0 V
7924	-24.0 V

LM-317 Variable IC Regulator: Also called adjustable voltage regulator.

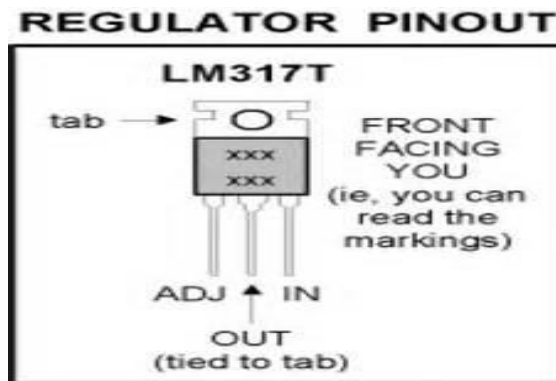

Pin-1 adjustable/variable , Pin-2  $V_{out}$  & Pin-3  $V_{in}$

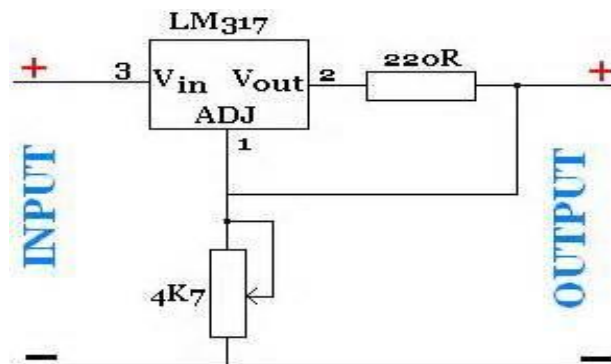

By varying the value of  $R_2$  the output voltage can be adjusted.

Here

$$V_{out} = 1.25 \left( \frac{R_2}{R_1} + 1 \right)$$

## Chapter Review Questions:

1. What is a regulator ?
2. State voltage regulation.
3. Explain load regulation .
4. Draw the circuit diagram of zener diode as a voltage regulator .
5. State the 78XX & 79XX fixed IC regulator.
6. Draw the basic block diagram of DC regulated power supply.
7. Draw the block diagram of LM 317 IC regulator.

## Chapter-6 Small Signal Amplifier

### 6.1 SINGLE STAGE CE AMPLIFIER WITH VOLTAGE DIVIDER BIAS

One of the primary uses of a transistor is to amplify ac signals. This could be an audio signal or perhaps some high frequency radio signal. It has to be able to do this without distorting the original input. The boundary between cutoff and saturation is called the linear region. A transistor which operates in the linear region is called a linear amplifier.

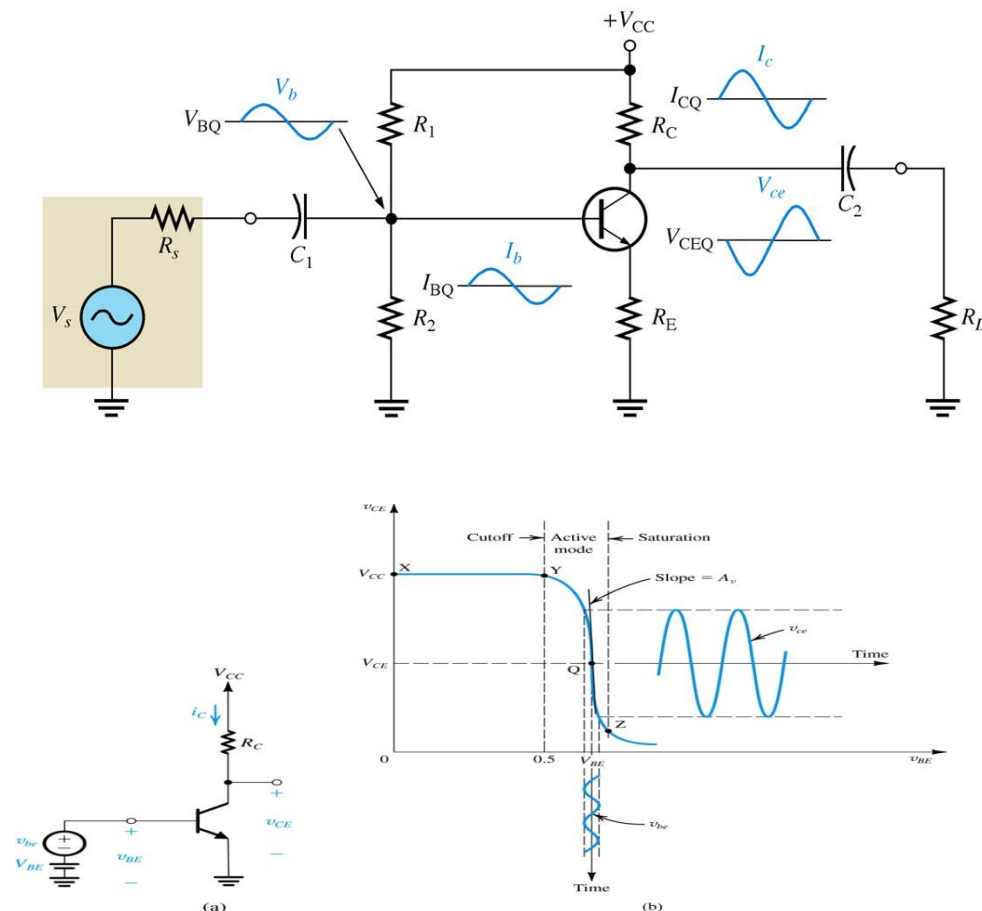

The above circuit shows the practical circuit of transistor amplifier with common emitter configuration. Resistance  $R_1$ ,  $R_2$  and  $R_E$  forms the biasing and stabilization circuit. The biasing circuit must establish a proper operating point otherwise a part of the negative half cycle of the signal may be cut off in the output. This circuit consists of three capacitors  $C_{in}$  or  $C_1$ ,  $C_E$ ,  $C_C$  or  $C_2$ .

1. **Input Capacitor ( $C_{in}$  or  $C_1$ ):**- Capacitor  $C_{in}$  is used to couple the signal to the base of the transistor. If it is not used the source resistance will come across  $R_2$  and thus change the bias.
2. **Emitter bypass Capacitor ( $C_E$ ):**- this capacitor is used in parallel with  $R_E$  to provide a low reactance path to the amplified a.c. signal.
3. **Coupling Capacitor ( $C_C$  or  $C_2$ ):**- Coupling capacitor couples one state of amplification to the next stage. To reduce the drastic change due to the shunting effect of  $R_C$ .

### 6.1 LOAD LINE ANALYSIS

A.C. load line is the line on the O/P characteristics of a transistor circuit which gives the value of  $i_C$  and  $v_{CE}$  when the signal is applied.

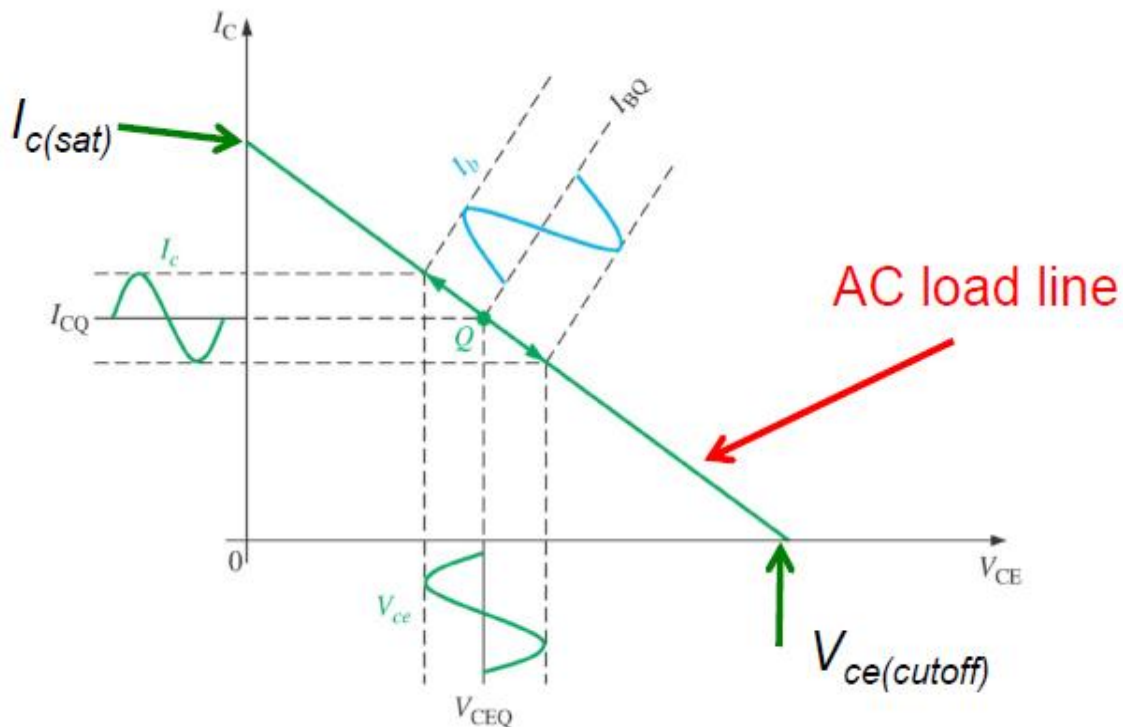

$$V_{CE \max} = V_{CE} + I_C R_{AC}$$

$$I_{C \max} = I_C + V_{CE} / R_{AC}$$

Where  $R_{AC} = R_C || R_L$

### VOLTAGE GAIN

The voltage gain of the amplifier is the ratio of a.c. output voltage to the a.c. input signal voltage. Therefore, to find the voltage gain, we should consider only the a.c. currents and voltages in the circuit.

A.C. load  $R_{AC} = R_C || R_L$

O/P Volt.  $V_{out} = i_c R_{AC}$

I/P Volt.  $V_{in} = i_b R_{in}$

Volt. Gain  $A_v = V_{out} / V_{in}$

$$A_v = i_c R_{AC} / i_b R_{in}$$

$$\Rightarrow A_v = \beta (R_{AC} / R_{in})$$

And Power gain  $A_p = \beta^2 (R_{AC} / R_{in})$

### **BEL AND DECIBEL**

The bel represented the power ratio of 10 to 1 between the strength or intensity i.e., power, of two sounds, and was named after Alexander Graham Bell. Thus a power ratio of 10:1 = 1 bel, 100:1 = 2 bels, and 1000:1 = 3 bels. It is readily seen that the concept of bels represents a logarithmic relationship since the logarithm of 100 to the base 10 is 2 (corresponding to 2 bels), the logarithm of 1000 to the base 10 is 3 (corresponding to 3 bels), etc. The exact relationship is given by the formula

$$\text{Bel} = \log (P_2 / P_1)$$

where  $P_2/P_1$  represents the power ratio.

Since the bel is a rather large unit, its use may prove inconvenient. Usually a smaller unit, the Decibel or dB, is used. 10 decibels make one bel. A 10:1 power ratio, 1 bel, is 10 dB; a 100:1 ratio, 2 bels, is 20 dB. Thus the formula becomes

$$\text{Decibels (dB)} = 10 \log(P_2 / P_1)$$

### **6.4 BANDWIDTH**

Bandwidth is defined as a band containing all frequencies between upper cut-off and lower cut-off frequencies. Upper and lower cut-off (or 3dB) frequencies corresponds to the frequencies where the magnitude of signal's Fourier Transform is reduced to half (3dB less than) its maximum value. Bandwidth enables computation of the power required to transmit a signal.

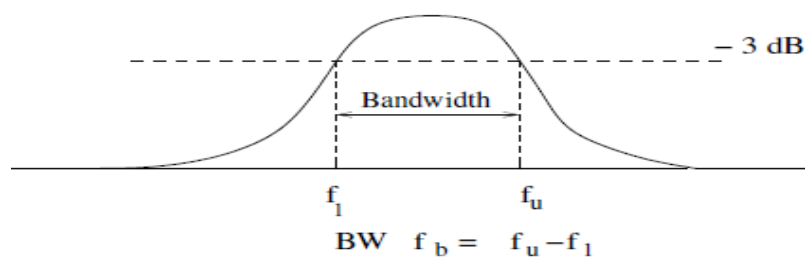

Where  $f_u$  is the upper cut-off frequency and  $f_l$  is the lower cut-off frequency.

## **6.5 MULTISTAGE OR CASCADE AMPLIFIERS**

A transistor circuit containing more than one stage of amplification is known as multi stage amplifiers.

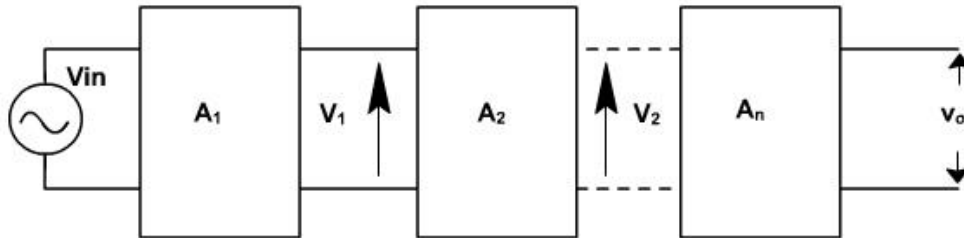

In a multistage of amplifier, a number of signal amplifier are connected in cascade arrangement i.e. o/p of first stage is connected to the i/p of the second stage through a suitable coupling device and so on. The purpose of coupling device is

- (i) To transfer a.c. o/p of one stage to the i/p of the next stage.
- (ii) To isolate the d.c. conditions of one stage from the next stage.

It is possible to create multistage cascade where each stage is separately biased and coupled to adjacent stages via DC blocking capacitors.

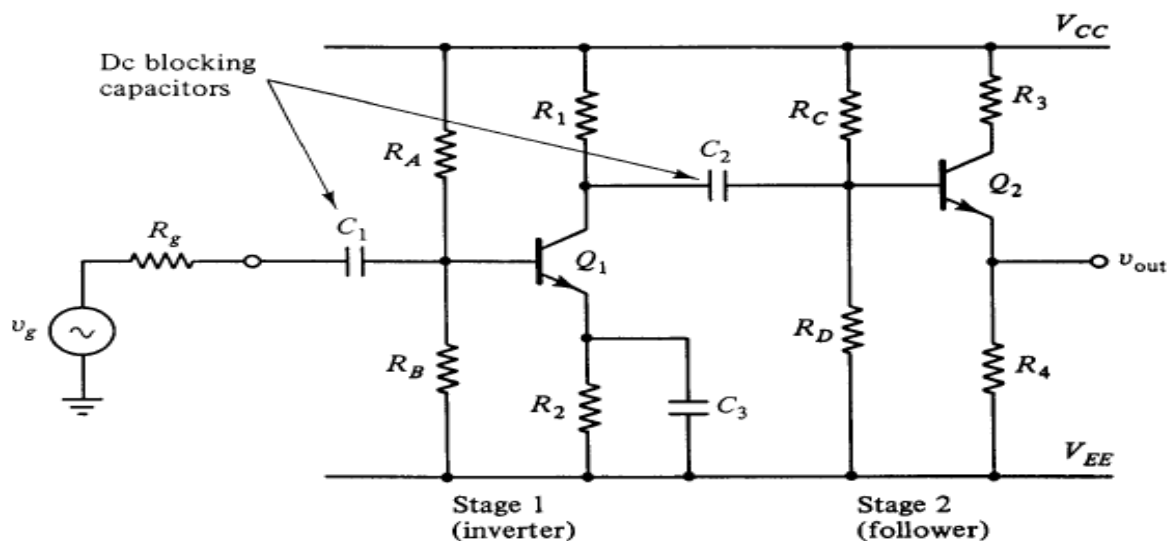

### **6.5.1 NEED OF MULTISTAGE AMPLIFIERS**

The gain of a single amplifier is inadequate for practical purpose to overcome this additional amplification over two or three stages are necessary. To achieve this o/p of each amplifier stage is coupled with the i/p of next stage.

The gain of a multistage amplifier is equals to product of gains of individual stages

The total power gain  $G_T = G_1 \times G_2 \times \dots \times G_n$

In dB  $G_T \text{ (dB)} = G_1 \text{ (dB)} + G_2 \text{ (dB)} + \dots + G_n \text{ (dB)}$

### Chapter review Questions

1. What is a regulator?
2. Explain need of regulators, voltage regulation factor
3. Explain Concept of load regulation & line regulation
4. Explain Basic zener diode as a voltage regulator
5. Define Linear Regulators
6. Explain Basics block diagram of dc power supply
7. Explain Regulator IC's – 78xx, 79xx & LM 317 as fixed, variable

## Chapter-7 Audio & Video Power & Oscillator

### 7.1 VOLTAGE AND POWER AMPLIFIERS

#### VOLTAGE AMPLIFIER

- The transistor with high  $\beta$  is used in the circuit. In other words, those transistor are employed which have thin base.
- The input resistance  $R_{in}$  of a transistor is sought to be quite low as compared to the collector load  $R_c$ .
- Relatively high load  $R_c$  is used in the collector. To permit this condition, voltage amplifiers are always operated at low collector current. If the collector current is small, we can use large  $R_c$  in the collector circuit.

#### POWER AMPLIFIER

- A power amplifier is required to deliver a large amount of power and as such it has to handle large current.
- The size of power transistor is made considerably larger in order to dissipate the heat produced in the transistor during operation.
- The base is made thicker to handle larger current.

### 7.2 OSCILLATORS

The use of positive feedback that results in a feedback amplifier having closed-loop gain  $|A_f|$  greater than 1 and satisfies the phase conditions will result in operation as an oscillator circuit. An oscillator circuit then provides a varying output signal. If the output signal varies sinusoidally, the circuit is referred to as a sinusoidal oscillator. If the output voltage rises quickly to one voltage level and later drops quickly to another voltage level, the circuit is generally referred to as a pulse or square-wave oscillator.

## Essentials of Oscillators

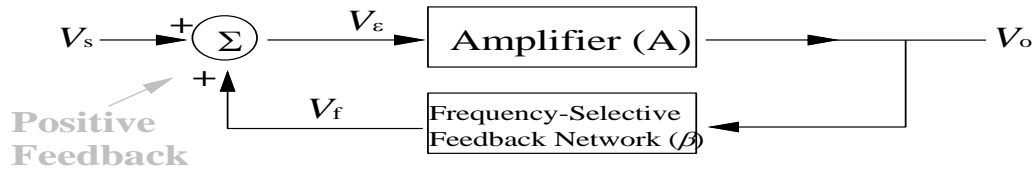

For sinusoidal input is connected "Linear" because the output is approximately sinusoidal

A linear oscillator contains:

- a frequency selection feedback network
- an amplifier to maintain the loop gain at **unity**

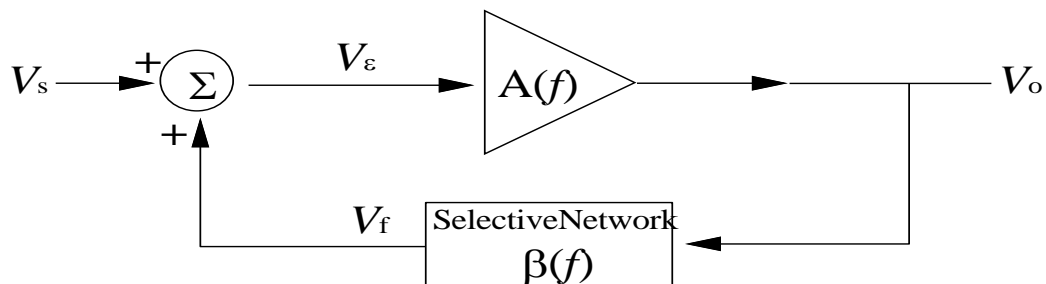

$$V_o = AV_\epsilon = A(V_s + V_f) \quad V_f = \beta V_o$$

$$\Rightarrow \frac{V_o}{V_s} = \frac{A}{1 - A\beta}$$

## APPLICATION OF OSCILLATORS

- Oscillators are used to generate signals, e.g.
- Used as a local oscillator to transform the RF signals to IF signals in a receiver;
- Used to generate RF carrier in a transmitter
- Used to generate clocks in digital systems;
- Used as sweep circuits in TV sets and CRO.

## TYPES OF OSCILLATORS

1. Wien Bridge Oscillators
2. RC Phase-Shift Oscillators
3. LC Oscillators
4. Crystal Oscillator
5. Colpitt's Oscillator



6. Tuned collector Oscillators
7. Hartley Oscillators

### Chapter Review Questions

1. Define Concept of amplification
2. Define Small signal amplifier using BJT power gain voltage gain.
3. Define AC Load Line.
4. What is Function of Input & Output coupling capacitors & criteria for the value selection.
5. What is Function of emitter bypass capacitor & its value selection.
6. Explain AC equivalent circuit of transistor CE amplifier.
7. Explain Single stage CE amplifier with voltage divider biases its explanation.
8. Explain Frequency response of single stage CE Amplifier,
9. Define Bel, Decibel unit, Bandwidth & its significance.
10. What are Effect of coupling & emitter bypass capacitor on bandwidth.
11. What is Cascade Amplifiers (Multistage Amplifier)
12. Explain Need of Multistage Amplifiers, Gain of amplifier.

## Chapter-8 Transducers and Measuring Instruments

### 8.1 TRANSDUCERS

- A transducer is a device that converts one form of energy to other form. It converts the measurand to a usable electrical signal.
- In other word it is a device that is capable of converting the physical quantity into a proportional electrical quantity such as voltage or current.

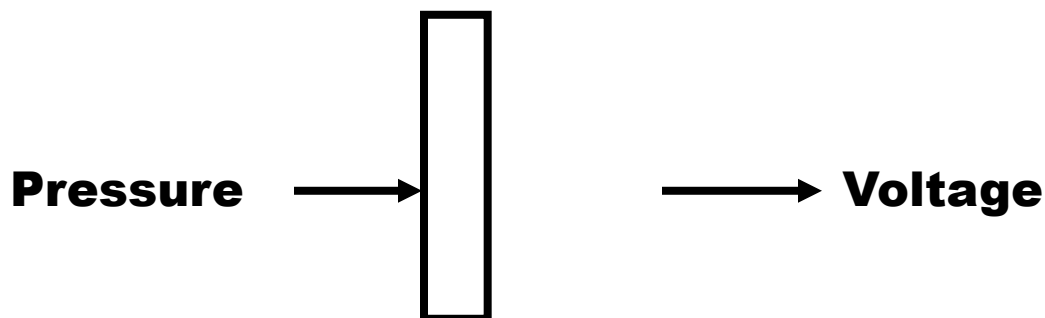

### BLOCK DIAGRAM OF TRANSDUCERS

- Transducer contains two parts that are closely related to each other i.e. the sensing element and transduction element.
- The sensing element is called as the sensor. It is device producing measurable response to change in physical conditions.
- The transduction element converts the sensor output to suitable electrical form.

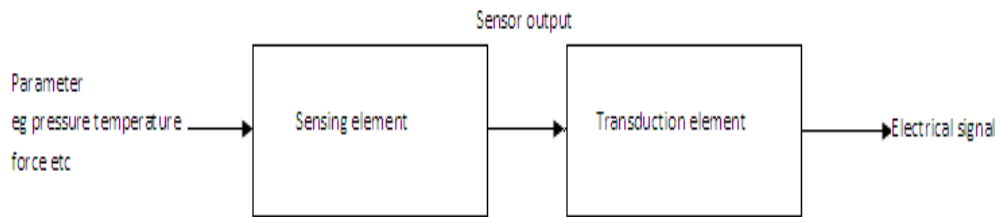

## **CHARACTERISTICS OF TRANSDUCERS**

1. Ruggedness
2. Linearity
3. Repeatability
4. Accuracy
5. High stability and reliability
6. Speed of response
7. Sensitivity
8. Small size

## **8.2 CLASSIFICATION OF TRANSDUCERS**

The transducers can be classified as:

- I. Active and passive transducers.
- II. Analog and digital transducers.
- III. On the basis of transduction principle used.
- IV. Primary and secondary transducer
- V. Transducers and inverse transducers.

## **8.3 Discuss working of thermocouple & its application**

A thermocouple is a temperature-measuring device consisting of two dissimilar conductors that contact each other at one or more spots. It produces a voltage when the temperature of one of the spots differs from the reference temperature at other parts of the circuit. Thermocouples are a widely used type of temperature sensor for measurement and control, and can also convert a temperature gradient into electricity.

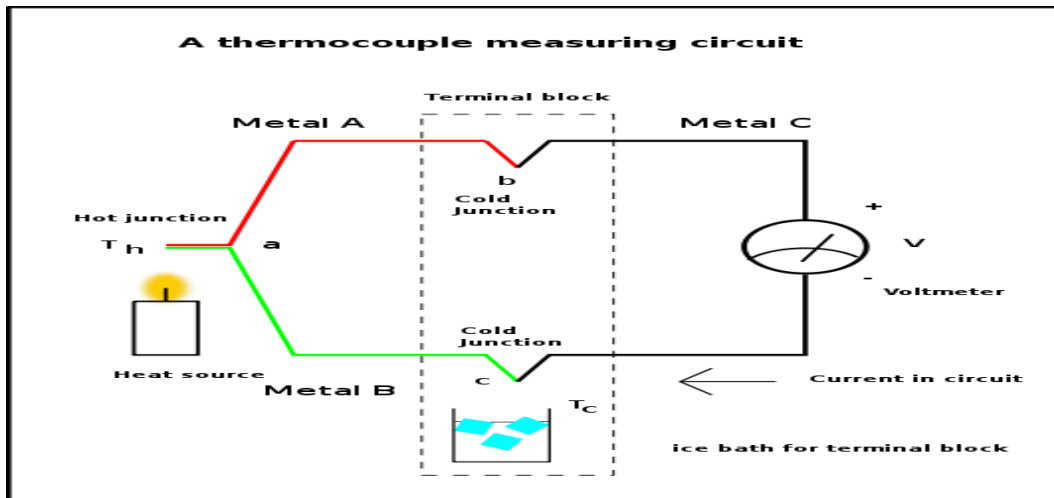

The voltage is not generated at the junction of the two metals of the thermocouple but rather along that portion of the length of the two dissimilar metals that is subjected to a temperature gradient. Because both lengths of dissimilar metals experience the same temperature gradient, the end result is a measurement of the difference in temperature between the thermocouple junction and the reference junction. As long as the junction is at a uniform temperature, it does not matter how the junction is made (it may be brazed, spot welded, crimped, etc.), however it is crucial for accuracy that the *leads* of the thermocouple maintain a well-defined composition. If there are variations in the composition of the wires in the thermal gradient region (due to contamination, oxidation, etc.), outside the junction, this can lead to changes in the measured voltage.

#### 8.4 Explain working of multimeter and comparison between Analog and Digital multimeter

##### WORKING OF MULTIMETER

To measure voltage (a.c., d.c.), current (ac, dc) and resistance, two types of instruments, analog and digital meters, are utilized. The measurements of these fundamental electrical quantities are based on either one of the following:

- i) Current sensing. The instruments are mostly of the electromagnetic meter movement type, such as an analog multimeter.
- ii) Voltage sensing. The instruments are mostly electronic in nature, using amplifiers and semiconductor devices, such as a digital multimeter.

Block Diagram

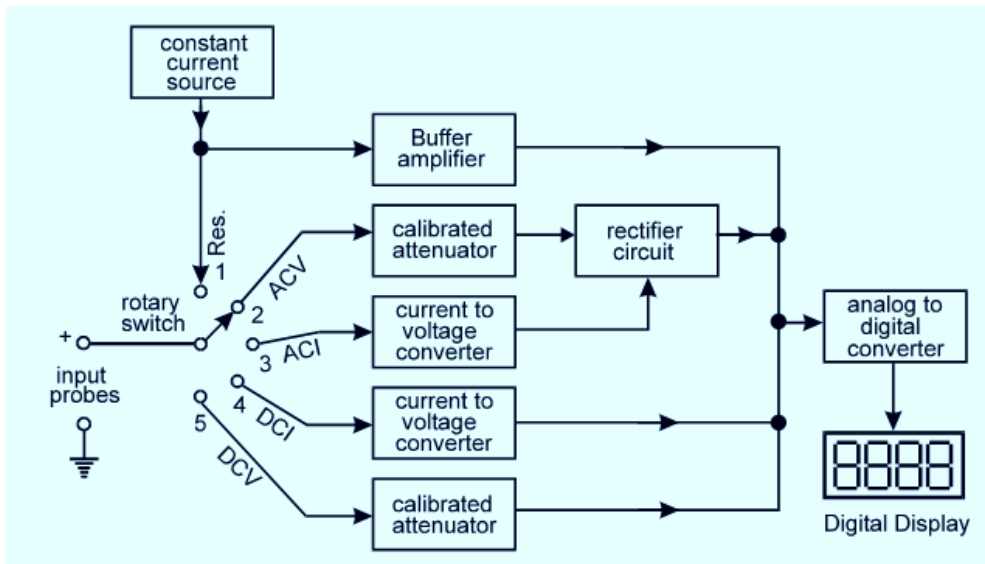

### **ANALOG MULTIMETER**

The main part of an analog multimeter is the D'Arsonval meter movement also known as the permanent-magnet moving-coil (PMMC) movement. This common type of movement is used for dc measurements.

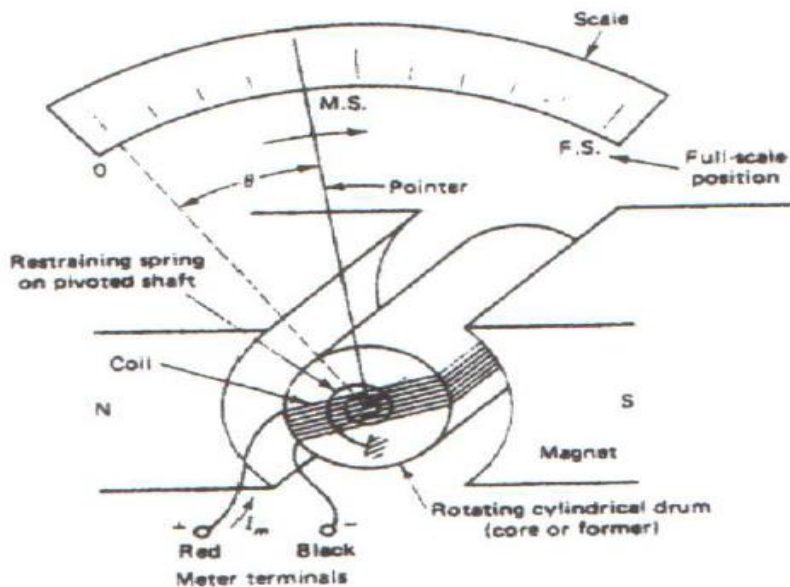

When the meter current  $I_m$  flows in the wire coil in the direction indicated in Figure, a magnetic field is produced in the coil. This electrically induced magnetic field interacts with the magnetic field of the horseshoe-type permanent magnet. The result of such an interaction is a force causing a mechanical torque to be exerted on the coil. Since the coil is wound and permanently fixed on a rotating cylindrical drum as shown, the torque produced will cause the rotation of the drum around its pivoted shaft. When the drum rotates, two restraining springs,

one mounted in the front onto the shaft and the other mounted onto the back part of the shaft, will exhibit a counter torque opposing the rotation and restraining the motion of the drum. This spring-produced counter torque depends on the angle of deflection of the drum,  $\theta$ , or the pointer. At a certain position (or deflection angle), the two torques are in equilibrium. Each meter movement is characterized by two electrical quantities:

1.  $R_m$ : the meter resistance which is due to the wire used to construct the coil.
2. IFS: the meter current, this causes the pointer to deflect all the way up to the full-scale position on the fixed scale. This value of the meter current is always referred to as the full-scale current of the meter movement.

**Pre Knowledge:**

**AMMETER**

The deflection of the pointer in the D'Arsonval meter movement is proportional to the meter current  $I$ . Therefore, this instrument can be used to measure current. However, the meter movement by itself is of limited use and capability, since its full-scale current value IFS is practically too small (at most in the order of milliamperes). If the current allowed to flow in the movement,  $I_m$ , exceeds IFS, permanent damage can result, in particular to the restraining springs.

To be able to measure currents higher in value than IFS of a given meter movement, the division principle is applied. Figure 4 shows the construction of an ammeter.

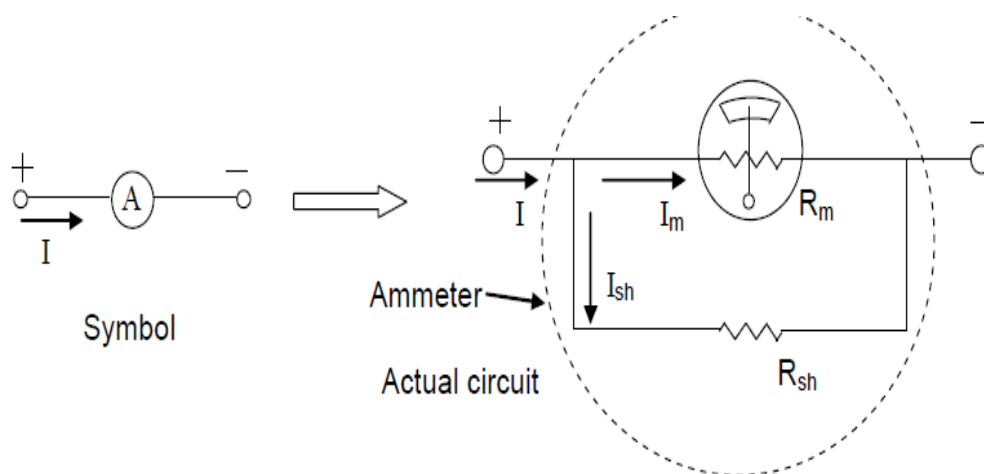

A given meter movement can be used to build a multirange ammeter. Each range requires a different value of the shunt resistance. So a three-range ammeter requires three different shunt resistors.

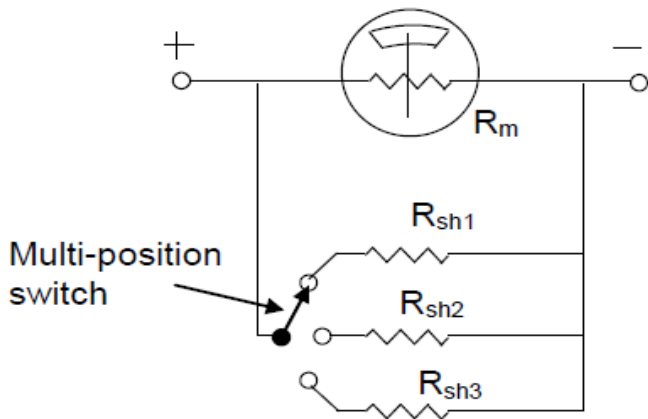

### **VOLTMETER**

To increase the full-scale voltage range of the movement when functioning as a voltmeter, the meter movement current  $I_m$  has to be lowered. This can easily be achieved by inserting a large resistance, called the multiplier resistance,  $R_{mult}$ , in series with the meter movement

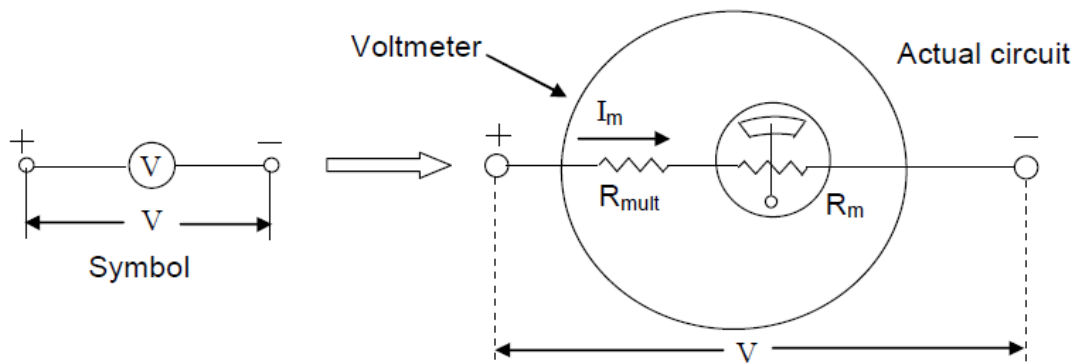

Using the same meter movement, a multirange voltmeter can be designed. A three-range Voltmeter

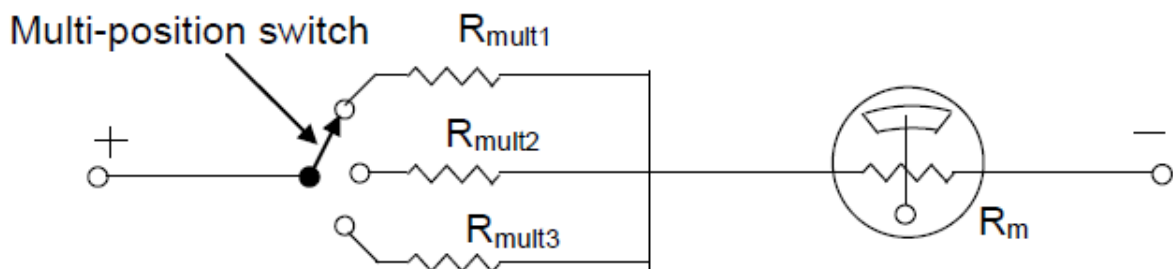

### **OHMMETER**

If the meter movement current  $I_m$  is somehow made to be proportional to the value of an unknown resistance to be measured, the meter's scale can be calibrated to read resistance

directly. Here, however, a voltage source (e.g., a battery) must be added to the meter's circuit to drive the current necessary for the deflection of the pointer.

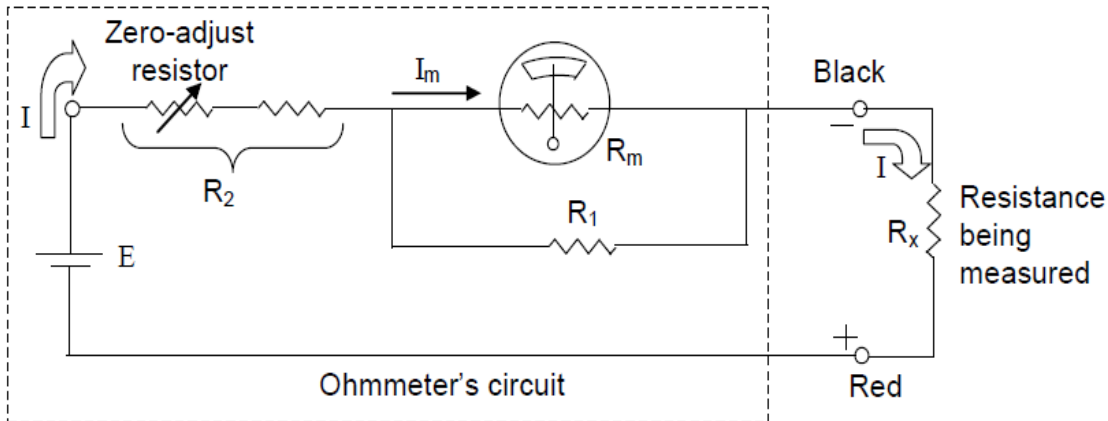

### **COMPARISON BETWEEN ANALOG AND DIGITAL MULTIMETER**

1. Analog multimeter use a needle and calibrated scale to indicate values where as digital multimetres display those values in a digital display.
2. Digital meters are easier to read and adjust to a proper range required for the circuit or device.
3. Digital voltmeters have 50 times more impedance than analog voltmeter. So digital meters are more accurate when measuring voltage in high resistance circuit.
4. Digital meters are often capable of measuring smaller current in microamperes and easier than analog ammeters.
5. Many analog ohmmeter will, when switched to the ohm function, reverse the polarity of the tested leads where as this problem is not happened in digital ohmmeter.

**8.5 Explain Block diagram of CRO, Measurement (Frequency & amplitude)& its use.**

### **CATHODE RAY OSCILLOSCOPE (CRO)**

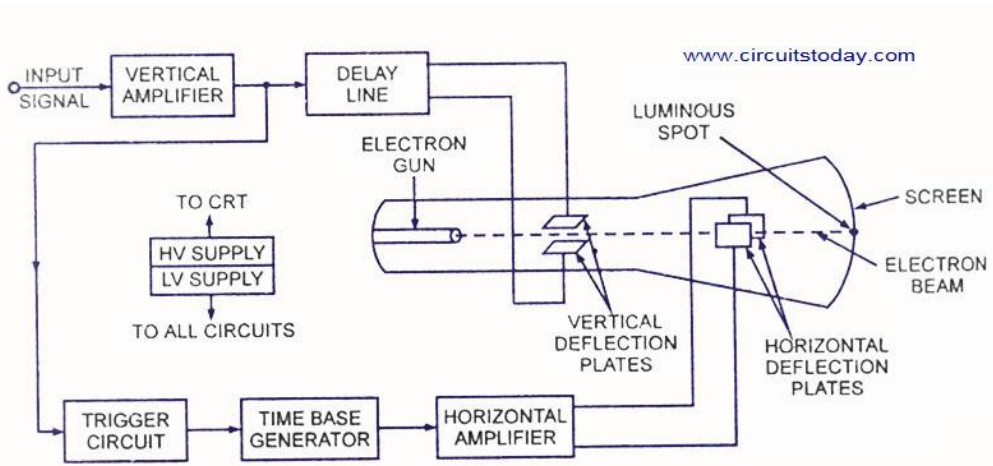
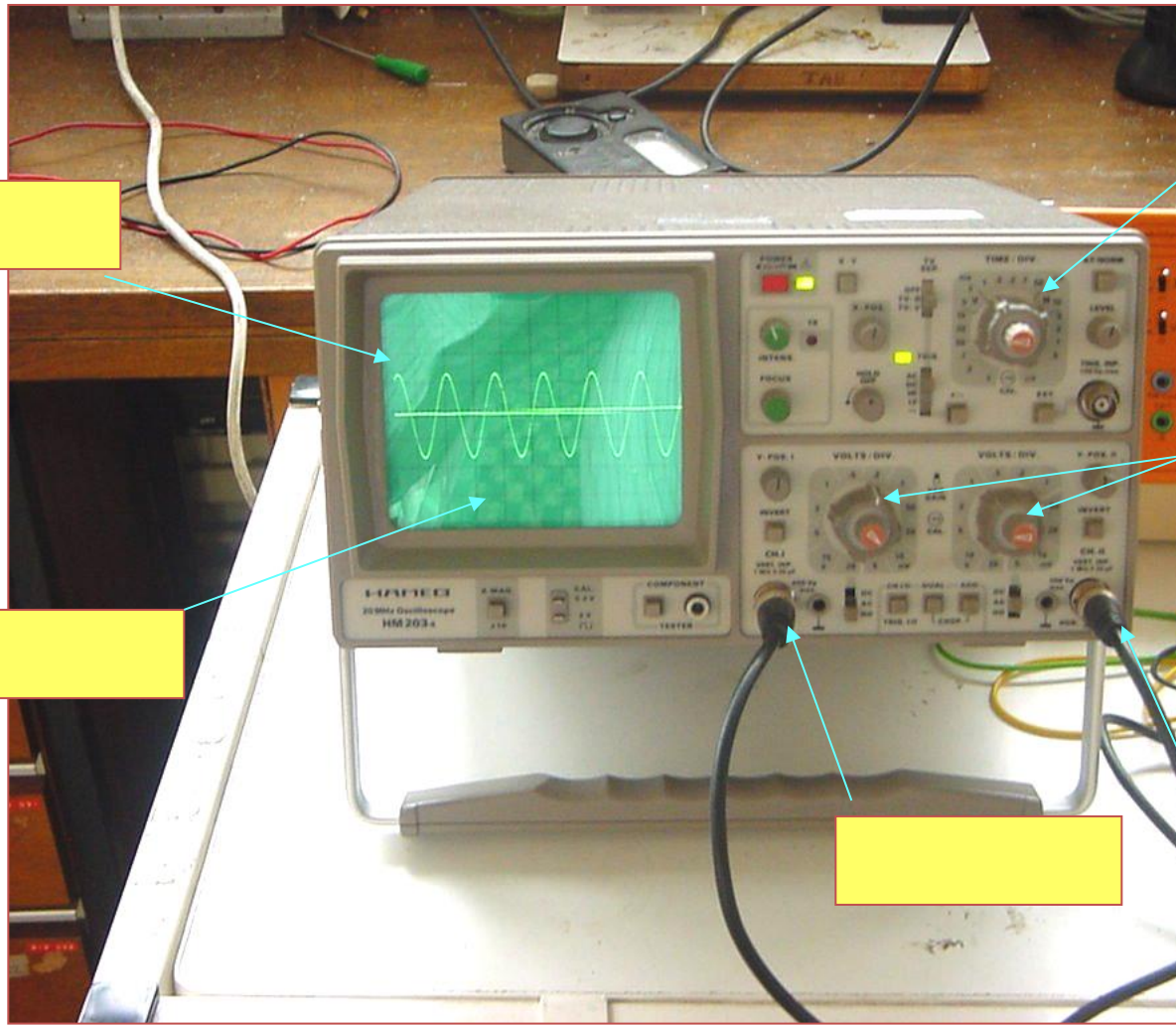
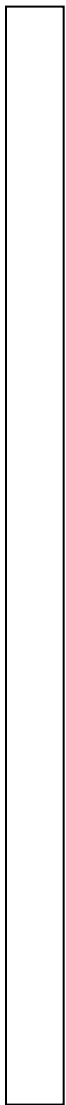

*Block Diagram of a General Purpose CRO*

- Popular instrument to show time, voltage both in D.C. and A.C. Shows Volts / Time.
- Display waveforms. Spectrum scope shows volts to Frequency



- Cathode (-ve) is heated, emits electrons, accelerated toward a (+ve) fluorescent screen. Intensity grid, Focus grid, accelerating anode. (Electron gun)
- Horizontal deflection plates.
- Vertical deflection plates

Cathode ray tube (CRT) is the heart of the CRO. Electron beam generated by the electron gun first deflected by the deflection plates, and then directed onto the fluorescent coating of the CRO screen, which produces a visible light spot on the face plane of the oscilloscope screen.

It consist of two main parts:-

- Electron Gun
- Deflection System

### ELECTRON GUN

Electron gun provides a sharply focused electron beam directed toward the fluorescent-coated screen. The thermally heated cathode emits electrons in many directions. The control grid provides an axial direction for the electron beam and controls the number and speed of electrons in the beam.

### THE DEFLECTION SYSTEM

The deflection system consists of two pairs of parallel plates, referred to as the vertical and horizontal deflection plates. One of the plates in each set is permanently connected to the ground (zero volt), whereas the other plate of each set is connected to input signals or triggering signal of the CRO.

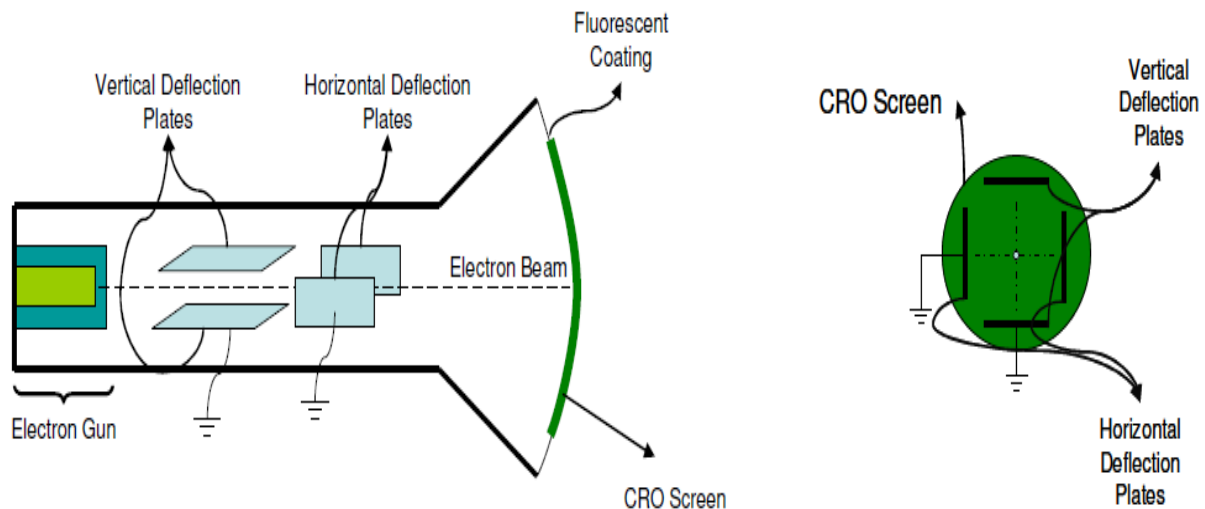

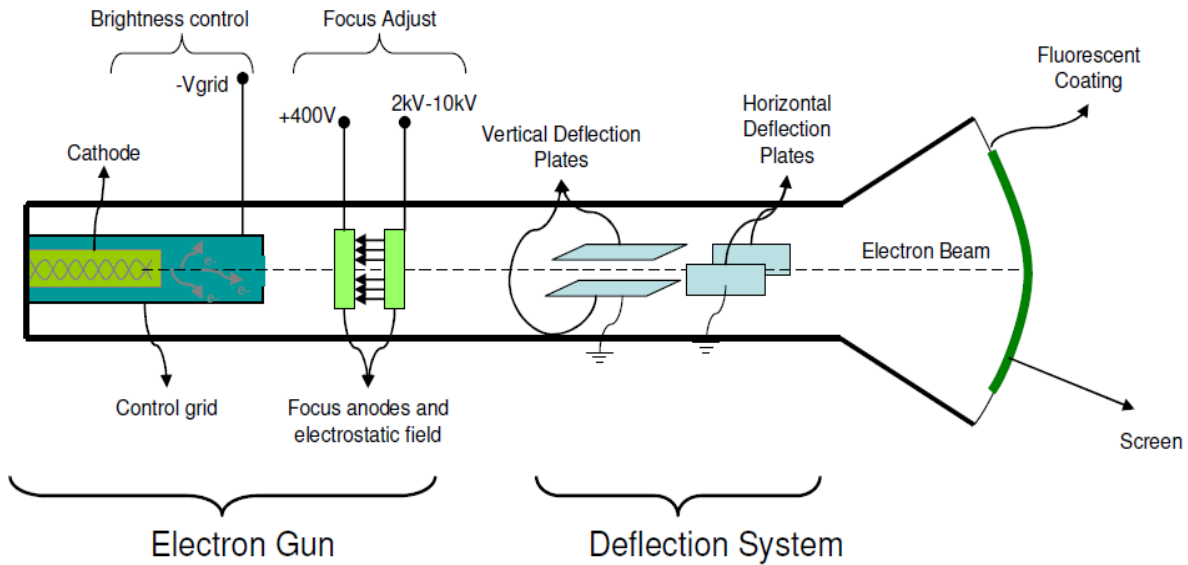

**Y-input:** It is the main input of CRO, to which the input signal is connected. The waveform of this input signal is displayed on the screen of CRT.

**Vertical attenuator<sup>1</sup>:** It consists of RC voltage divider, which is marked on the CRO front panel as Volt/div control knob. Thus the 'gain' of CRO can be controlled with Volt/div knob.

**Vertical amplifier:** It is a set of preamplifier and main vertical amplifier. The input attenuator sets up the gain of vertical amplifier.

**Delay line:** The delay line delays the striking of electron beam on the screen. It synchronizes the arrival of the beam on screen when time base generator signal starts sweeping the beam horizontally. The **propagation delay<sup>2</sup>** produced is about 0.25msec.

**Trigger circuit:** It takes the sample of input voltage connected at y-input of CRO and feeds it to the input of time base generator. So the TBG starts only when input signal is present at y-input.

**Time base generator:** It produces a saw tooth wave. The waveform is used to sweep (move) the electron beam horizontally on the screen. The rate of rise of positive going edge of saw tooth waveform is controlled by Time/div control knob. Thus, the saw tooth wave controls the horizontal deflection of electron beam along x-axis.

A switch known as INT/EXT is also connected after the output of TBG. When the switch is in INT position, the output of TBG is connected to H-plates through horizontal amplifier. When it is in EXT position, internal saw tooth is cut-off and some external signal can be connected to horizontal plates.

**Horizontal amplifier:** It amplifies the saw tooth waveform coming from TBG. It contains phase inverter circuit also. Due to this circuit, two outputs are produced. One output produces positive going saw tooth and other output produces negative going saw tooth. The first output is connected to right side H-plate and the second output is connected to left side H-plate. So the electron beam moves properly from left to right of the screen.

**Blanking circuit:** It is necessary to eliminate the retrace, which would produce when the spot on screen moves from *right to left*. This retrace can produce confusion with the original wave.

So when the electron beam reaches right end of screen, the negative blanking voltage is produced by TBG. It is fed to control grid of CRT, to stop the electron beam completely.

**HV/LV power supply:** The high voltage section is used to power the electrodes of CRT and the low voltage section is used to power the electronic circuits of the CRO.

### Applications of CRO

Some important applications of CRO are :

1. Observation of waveforms
2. Voltage measurement
3. Frequency measurement
4. Measurements using Lisajous pattern
5. Identification of Components(New type CRO)

### Chapter review questions

1. Define transducer.
2. Classify different type of transducers.
3. Discuss working of thermocouple & its application
4. Explain working of multimeter with neat block diagram
5. comparison between Analog and Digital multimeter
6. Explain Block diagram of CRO, Measurement(Frequency & amplitude)& its use.
7. What is CRO
8. What are different sections of CRO

## Chapter-9 Communication System

### Basics of Communication Systems

**Communication** is the transfer of information from one point in space and time to another point.

The block diagram of a communication system is shown in Figure 19.

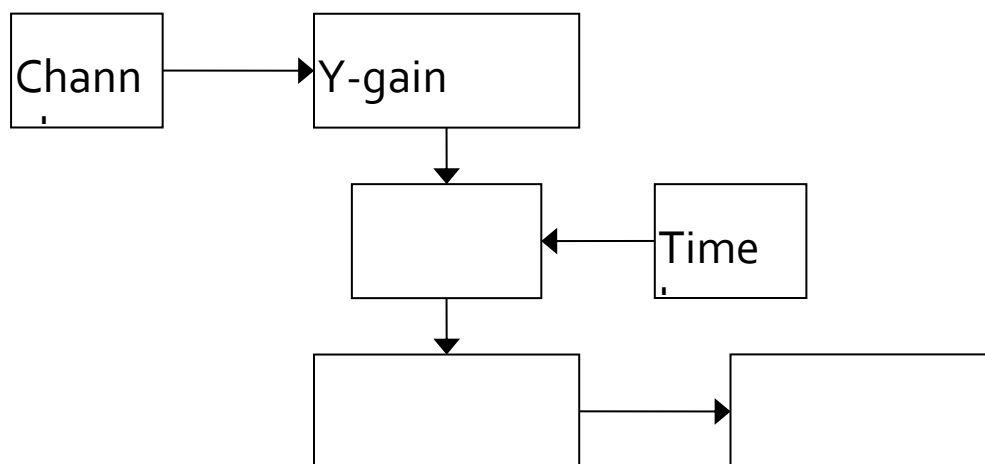

Figure 19 A block diagram of a communication systems

**Transmitter** - couples the message onto the channel using high frequency signals

**Receiver** - restores the signal to its original form

**Channel** - the medium used for transmission of signals and Channels can be of two types:  
i) wired channels or ii) wireless channels.

**Modulation** - the process of shifting the frequency spectrum of a message signal to a frequency range in which more efficient transmission can be achieved

**Demodulation** - the process of shifting the frequency spectrum back to the original baseband frequency range and reconstructing the original form, if necessary

**Baseband** - refers to the lower portion of the over-all electromagnetic spectrum

### Spectrum of Communication Systems

Frequency Designation	Transmission Media	Propagation Modes	Applications
Infrared 1 THz – 430 THz	Optical fibers	Laser beam	Wideband Data Multimedia ATM
Super High Frequency (SHF) 3 GHz – 30 GHz	Waveguides	Line-of-Sight (LOS) Radio	Satellite Microwave Radar Navigational
Ultra High F'cy (UHF) 300 MHz – 3000 MHz	Waveguides/ Co-axial cable	LOS Radio	UHF ,TV ,Mobile
Very High F'cy (VHF) 30 MHz – 300 MHz	Co-axial cable	LOS Radio	Mobile ,VHF ,TV, FM
High F'cy (HF) 3 MHz – 30 MHz	Co-axial cable	Sky wave Radio	CB Amateur Radio Civil Defense
Medium F'cy (MF) 300 kHz – 3000 kHz	Co-axial cable	Ground wave Radio	AM
Low F'cy (LF) 30 kHz – 300 kHz	Wire pairs	Ground wave Radio	Aeronautical , ransoceanic Radio
Very Low F'cy (VLF) 3 kHz – 30 kHz	Wire pairs	Ground wave Radio	Telephone Telegraph
Audio F'cy (AF) 20 Hz – 20 kHz	Wire pairs		

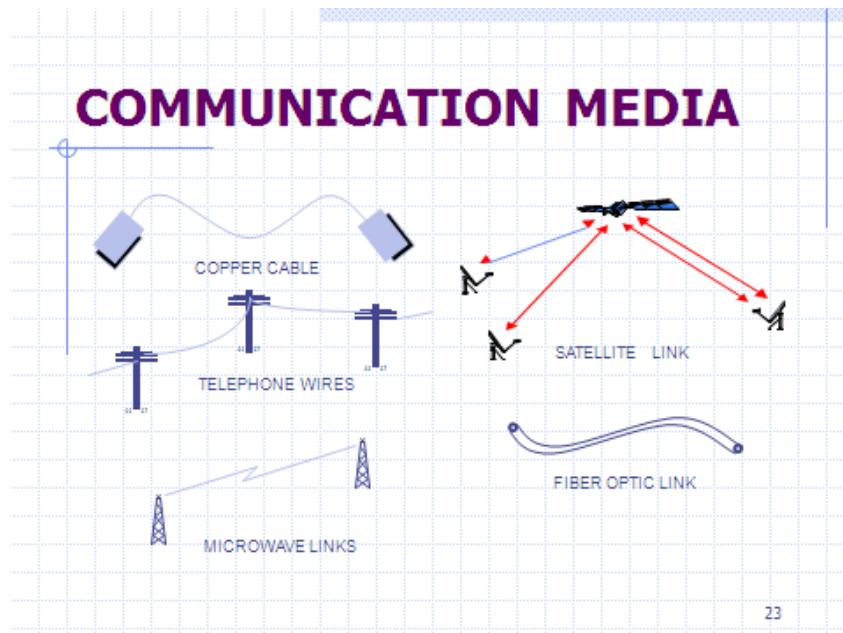

## 9.1 Define Modulation & its need.

The process of changing some characteristic (e.g. amplitude, frequency or phase) of a carrier Wave in accordance with the intensity of the signal is known as **modulation**. The resultant wave is called modulated wave or radio wave and contains the audio signal. Therefore, modulation permits the transmission to occur at high frequency while it simultaneously allows the carrying of the audio signal. It is also the process of manipulating the frequency or the amplitude of a carrier wave in response to an incoming voice, video or data signal

Why Modulation needed?

Modulation is required to match the signal to the transmission medium. Some of the major reasons why modulation is required are:

- **Practical antenna length.**  
Ex- Audio frequencies range from 20 Hz to 20 kHz, therefore, if they are transmitted directly into space, the length of the transmitting antenna required would be extremely large. For instance, to radiate a frequency of 20 kHz directly into space, we would need an antenna length of  $3 \times 10^8 / 20 \times 10^3 = 15,000$  metres. This is too long antenna to be constructed practically. If a carrier wave say of 1000 kHz is used to carry the signal, we need an antenna length of 300 metres only and this size can be easily constructed.
- **Operating range.** The energy of a wave depends upon its frequency. The greater the frequency of the wave, the greater the energy possessed by it. As the audio signal frequencies are small, therefore, these cannot be transmitted over large distances if radiated directly into space. Thus modulate a high frequency carrier wave with audio signal and permit the transmission to occur at this high frequency (*i.e.* carrier frequency).
- **Wireless communication.** One desirable feature of radio transmission is that it should be carried without wires *i.e.* radiated into space. At audio frequencies, radiation is not practicable because the efficiency of radiation is poor. However, efficient radiation of electrical energy is possible at high frequencies > 20 kHz.
- Modulation for ease of radiation
- Modulation for frequency assignment and multiplexing
- Modulation to reduce noise and interference

## 9.2 Types of Modulation

There are three basic types of modulation, namely ;

- (i) Amplitude modulation      (ii) Frequency modulation      (iii) Phase modulation

### (i) Amplitude Modulation

When the amplitude of high frequency carrier wave is changed in accordance with the intensity of the signal, it is called **amplitude modulation**. In amplitude modulation, only the amplitude of the carrier wave is changed in accordance with the intensity of the signal and the frequency of the modulated wave remains the same i.e. carrier frequency. Amplitude modulation (AM) is a **modulation** technique used in electronic communication, most commonly for transmitting information via a **radio carrier wave** and in portable **two way radios**, **VHF aircraft radio** and in computer **modems** ."AM" is often used to refer to **medium wave AM radio broadcasting**.

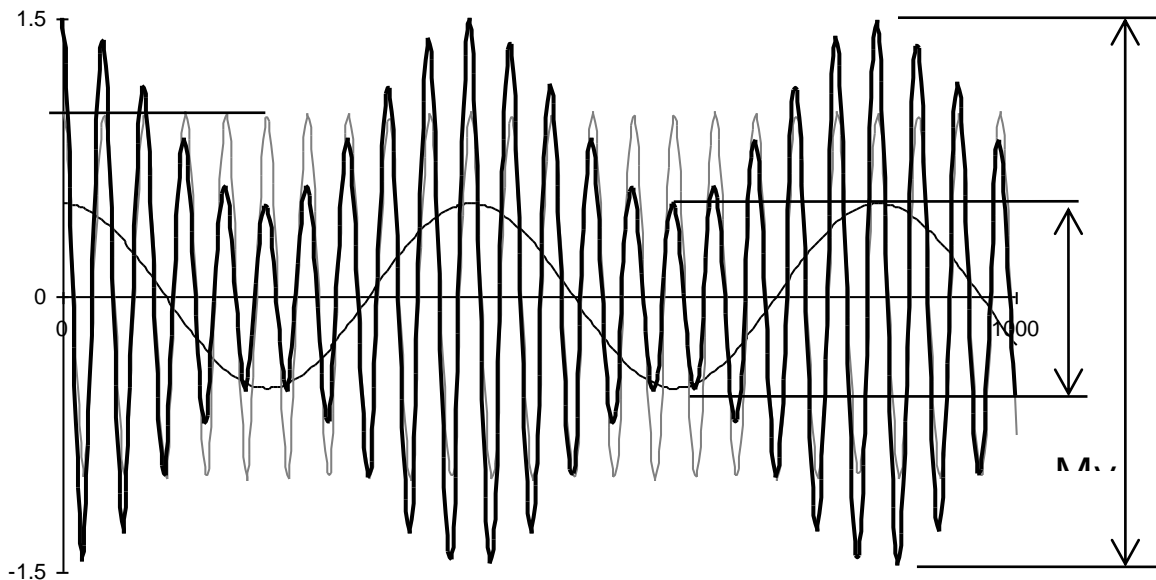
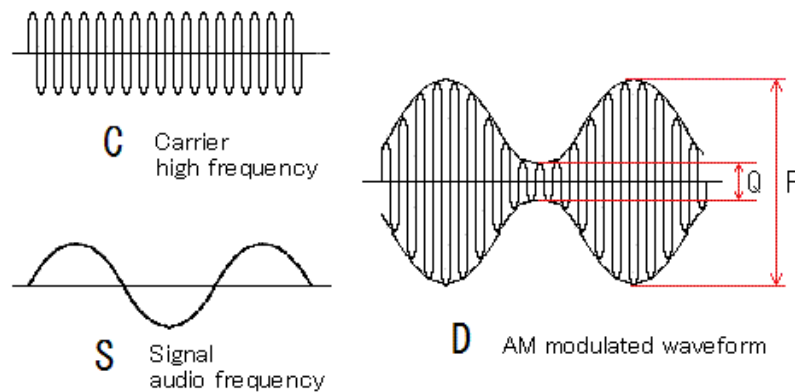
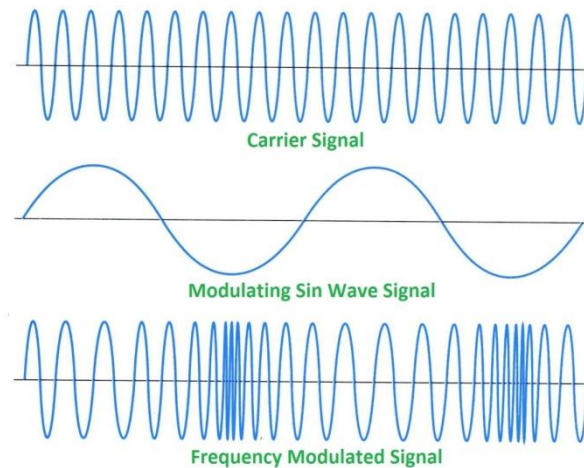

Figure1.2 An AM signal with modulating and carrier signals shown

### (ii) Frequency Modulation (FM)

When the frequency of carrier wave is changed in accordance with the intensity of the signal, it is called **frequency modulation (FM)**. In frequency modulation, only the frequency of the

carrier wave is changed in accordance with the signal and the amplitude of the modulated wave remains the same *i.e.* carrier wave amplitude. The frequency variations of carrier wave depend upon the instantaneous amplitude of the signal (Compare with **amplitude modulation**, in which the **amplitude** of the carrier wave varies, while the frequency remains constant.) It is used in **radio**, **telemetry**, **radar**, seismic prospecting, and monitoring **newborns** for seizures via **EEG**. FM is widely used for **broadcasting** music and speech, **two-way radio** systems, magnetic tape-recording systems and some video-transmission systems. Frequency modulation is known as **phase modulation** when the carrier phase modulation is the time **integral** of the FM signal



- (iii) Phase modulation (PM) is a **modulation** pattern that encodes **information** as variations in the **instantaneous phase** of a **carrier wave**. Phase modulation is a form of modulation that can be used for radio signals used for a variety of radio communications applications. As will be seen later, phase modulation, and frequency modulation are closely linked together and it is often used in many transmitters and receivers used for a variety of radio communications applications from two way radio communications links, mobile radio communications and even maritime mobile radio communications. Unlike **frequency modulation** (FM), phase modulation is not widely used for transmitting **radio** waves. It is used for signal and waveform generation in **digital synthesizers**.

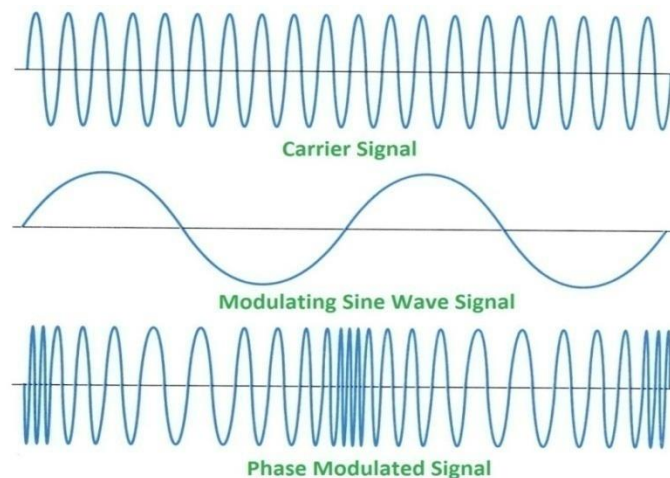

## 9.4 Demodulation

The process of recovering the audio signal from the modulated wave is known as **modulation** or **detection**. At the broadcasting station, modulation is done to transmit the audio signal over larger distances to a receiver. When the modulated wave is picked up by the radio

receiver, it is necessary to recover the audio signal from it. This process is accomplished in the radio receiver and is called demodulation. A demodulator is an electronic circuit (or computer program in a software defined radio) that is used to recover the information content from the modulated carrier wave. Demodulation is the act of extracting the original information-bearing signal from a modulated **carrier wave**. A demodulator is an **electronic circuit** (or **computer program** in a **software-defined radio**) that is used to recover the information content from the modulated **carrier wave**.

The comparison of FM and AM is given in the table below

FM	AM
The amplitude of carrier remains constant with modulation	The amplitude of carrier changes with Modulation
The carrier frequency changes according to the strength of the modulating signal.	The carrier frequency remains constant with modulation.
The carrier frequency changes with modulation.	The carrier amplitude changes according to the strength of the modulating signal
The value of modulation index (mf) can be more than 1.	The value of modulation factor (m) cannot be more than 1 for distortionless AM signal.

### Chapter Review Questions

1. Define communication system
2. Define Transmission & Reception.
3. Define Modulation & its need.
4. Define Signal, Carrier Wave & Modulated Wave
5. Name different types of Modulation.(AM,FM & PM)
6. Discuss Amplitude Modulation & draw its wave form
7. Discuss Frequency Modulation & draw its wave form.

\*\*\*\*\*